

VIALS



VERA X



Roads/
Urban roads



Residential
streets



Parking



Logistics
platforms



Stations



Bicycle lanes

VERAXHISPALED

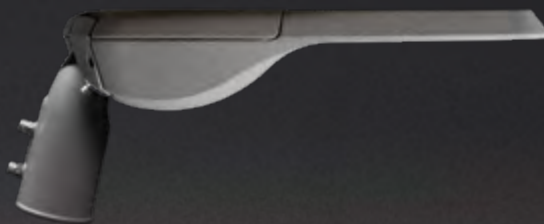



New generation of street lighting with an unbeatable price/performance ratio

PROFITABILITY AND EFFICIENCY

The Vera series is a compact luminaire, with a simplified line, ideal for residential streets and urban roads of low to moderate speed.

Lighting solution with maximum profitability and fast amortization. It allows to reduce energy costs and enjoy all the advantages of LED lighting, with a very low investment.

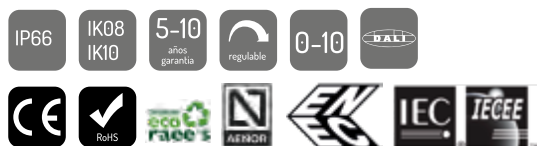

TECHNICAL DATA SHEET

ENEC 01; CE, RoHS; EN 60598-1:2009 + A1:2009; EN 60598-2-3:2003 + Corr:2005 + A1:2011; EN 62031:2009 + A1:2011; EN 62471:2008; IES LM-80; EN 61347-1:2008; EN 61347-2-13:2006; EN 55015:2006 + A1:2007 + A2:2009; EN 61547:2009; EN 61000-3-2:2006 + A1:2009 + A2:2009; EN 61000-3-3:2008; EN 61000-4-2,3,4,5,6,8,11; UL 8750; IEC 60598-1:2008; IEC 60598-2-3:2002; IEC 62031:2008; IEC 62471:2008; IES LM-80; IEC 61347-1:2008; IEC 61347-2-13:2006; IEC 55015:2006; + A1:2007 + A2:2009; IEC 61547:2009; IEC 61000-3:2006; A1:2009 + A2:2009; IEC 61000-3-3:2008; IEC 6100-4-2,3,4,5,6,8,11; UL 8750;

The Vera X Series offers solutions of up to 160W of power, guaranteeing optimal results in all types of streets and urban roads with minimum investment costs. Its die-cast aluminum structure with flat cover, and the arrangement of independent spaces for optical block and driver, provide excellent heat dissipation, guaranteeing a useful life of more than 100,000 hours of operation.

It is suitable for post-top or side-entry mounting, allowing tilt adjustment to adapt perfectly to the lighting needs of each track. Its lightweight appearance and tool-free opening makes it easy to install at height for the installer, with the option of an electrical disconnection system during opening, which offers maximum safety when handled. This road luminaire offers multiple lighting packages, with a wide range of photometric distributions and operating currents.

It allows plug & play installation of NEMA / ZHAGA socket compatible devices, ensuring easy integration with point-to-point remote management systems.

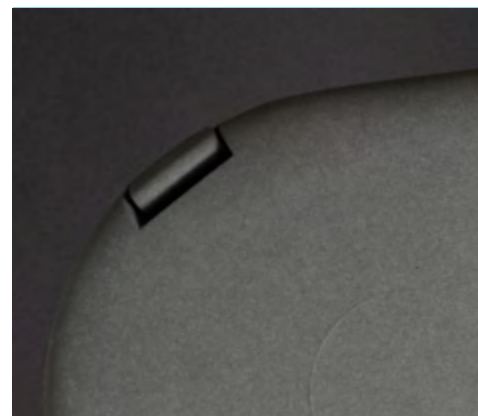
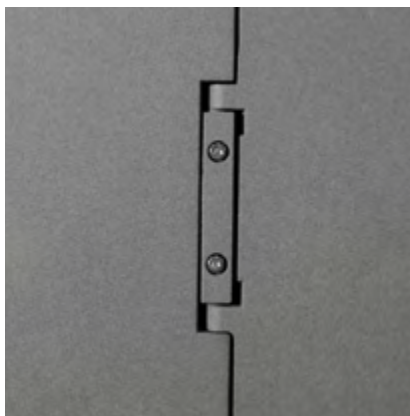

TECHNICAL DATA SHEET

VERA X

VERA*

Structure	Aluminum injection
Diffuser	Tempered glass/polycarbonate
Dimensions and weight	704x289x113 mm / 7.3 kg
Anchoring systems	Post-top and side Ø up to 65 mm with 0 to 90° rotation
Degree of protection	IP66, IK08 (IK10 optional)
Warranty	5/7/10 years
Certification	CE; RoHS
Safety class	I/II
Opening	Tool-free, with optional electrical disconnection.

OPTIONAL CONTROL SYSTEMS

Programmable regulation of up to 8 levels
 Time programming module
 (35 programs | reprogrammable from CM | winter-summer distinction)
 Point to point remote management RFLight₂
 DALI2/D4i, 1 -10V
 CLO (constant light level)
 Dimming at the head-end
 Control line dimming
 Photocell
 Socket NEMA 7 / Zhaga book 18
 Others: PLC, GPRS, 3G, NFC, NFC, Bluetooth, Narrow Band 5G

CHARACTERISTICS*

Power	40W-160W
Efficiency lm/W	Up to 170 lm/W
Input voltage	90-305 V / ~ 50-60Hz (depending on model)
Power supply	PF > 0.95, Efficiency > 88% (depending on model)
Lifetime	>100,000 hours (L90B10)
LED Type	Cree®, Nichia®, Osram®
Color temperature	1,800 K - 6,000 K / PC-Amber / RGB
Minimum CRI	70/80
FHS	0%

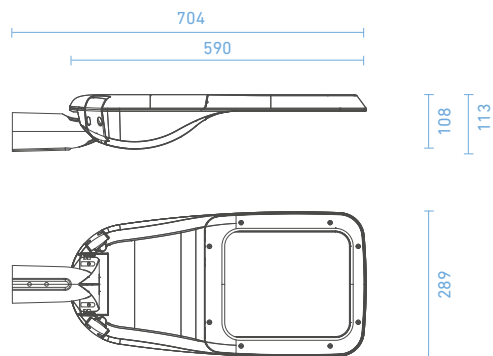

VERSIONS*

	ECO	STANDARD	PREMIUM	
OVERVOLTAGE PROTECTION				● Included ○ Optional ✗ Not available
10 kV (en f. alim.)	●	✗	✗	
10 kV (SPD ext.)	✗	●	●	
20 kV (SPD ext.)	✗	○	○	
REGULATION				
8 Levels	●	●	✗	
MPH (reprogrammable)	✗	○	●	
OPERATING CURRENT				
500 mA	○	○	●	
700 mA	○	●	○	
1000 mA	●	○	○	

OPTICAL BLOCK

(Consult for more optical options)



ROAD I	ROAD II	ROAD III	ROAD IV	URBAN 360
Recommended distribution on tracks with extreme spacings up to 6 times the pole height	Recommended layout for roadways with a track width similar to the height of the pole	Recommended layout for roadways with up to two lanes with spacings up to 4 times the pole height.	Recommended distribution on tracks with high clearances of up to 5 times the height of the pole	Recommended distribution for medium-height omnidirectional lighting, such as parks and squares

* Specifications are subject to change



GALICIA
ORDES CITY COUNCIL (A CORUÑA)
Installation of Hispaled's VERA luminaires.