



RFLIGHT₂ A different city

RFLight₂

INTEGRAL MANAGEMENT OF STREET LIGHTING

RFLight₂ NODES

TECHNOLOGIES: RADIO FREQUENCY (LoRa) - NARROW BAND - GPRS - PLC



HISPALED's RFLight₂ is one of the most advanced remote management systems for street lighting on the market. RFLight Web allows both the luminaires and the control centres of any installation to be managed via a simple and intuitive interface. This ensures that resources are utilised to the full in an efficient manner, maintenance costs are reduced, and a higher quality of lighting is guaranteed across the municipality, with individualised control of light points and electrical panels.

- RFLIGHT₂ SYSTEM**
- > Node RFLight₂ Fitting terminals
 - > LTM RFLight₂ LTM Panel Monitoring
 - > RFLight₂ Gateway Gateway
 - > RFLight₂ Geo Installation and inventory app
 - > RFLight₂ Web Web-based Lighting Management Platform

RFLIGHT₂ ARCHITECTURE

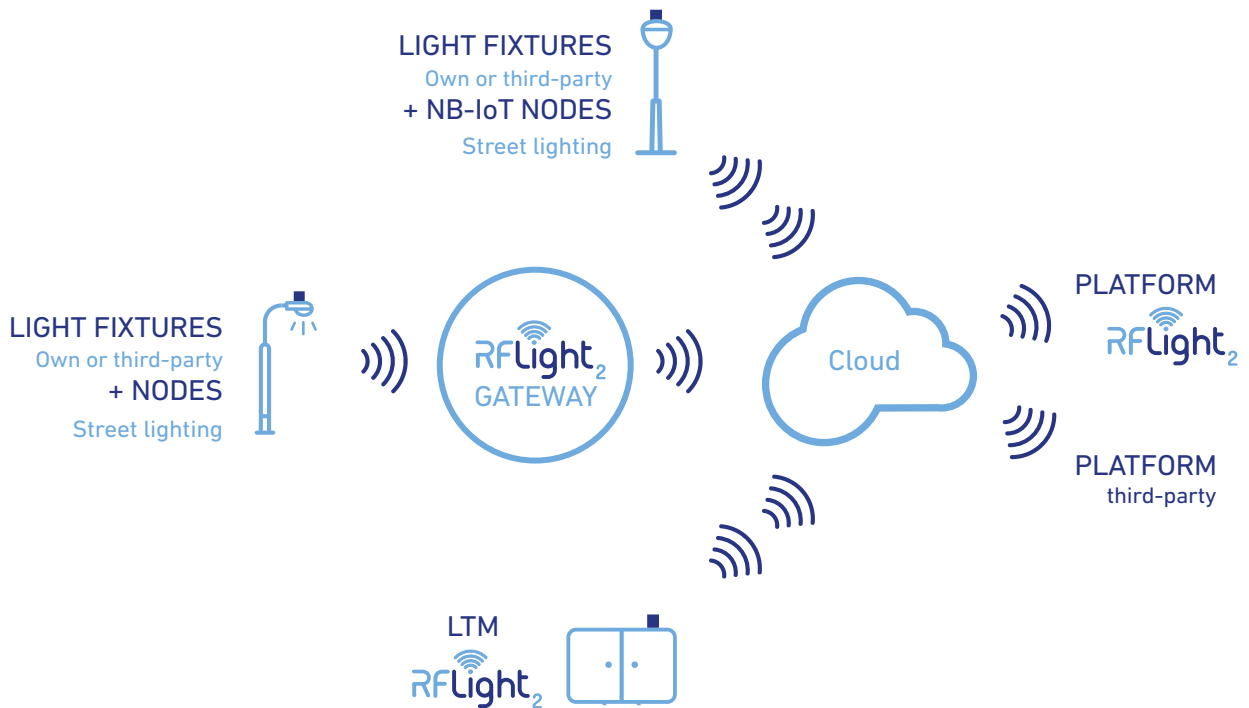

RFLight₂ enables the remote management of luminaires from both HISPALED and other manufacturers. Our open system can be integrated into any web-based lighting management platform.

RFLight₂ enables remote management of control centres and luminaires, whether from HISPALED or other manufacturers, and integrates with any web platform – whether proprietary or third-party – from which to operate lighting panels and individual luminaires, reporting information and enabling comprehensive management and control of the lighting system.

CUSTOM-MADE SOLUTIONS

TECHNICAL SPECIFICATIONS OF THE RFLIGHT₂ NODES:

HispaLED's RFLight₂ nodes for street lighting incorporate the very latest communications technologies: radio frequency, narrowband, 3G/4G, PLC, etc. This enables us to adapt to any technical solution required by the local authority.

Depending on their CONNECTIVITY, we distinguish between two types of HispaLED RFLight₂ nodes:

NARROW BAND NODES

CONNECTIVITY TYPES FOR RFLIGHT₂ NODES:

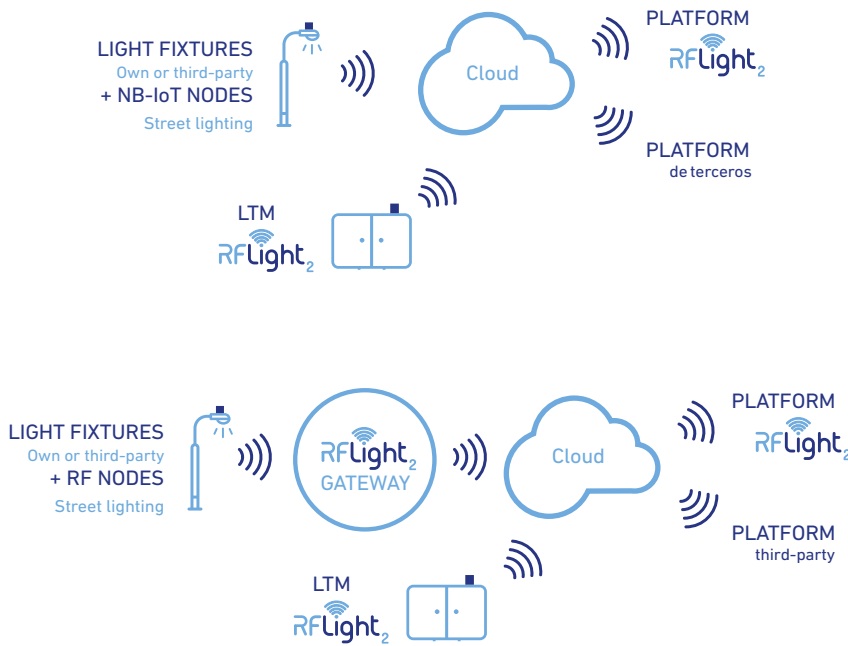

The streetlights form a communications network in which each streetlight acts as a node. Each of these nodes is capable of sending or receiving information to or from any other node.

Working in the cloud offers key advantages: automatic scalability, greater availability and reduced infrastructure costs. It also ensures robust security, regular updates and global accessibility. This enables systems to be flexible and efficient, adapting to market demands without the need for hardware modifications.

RADIO FREQUENCY NODES (LoRa)

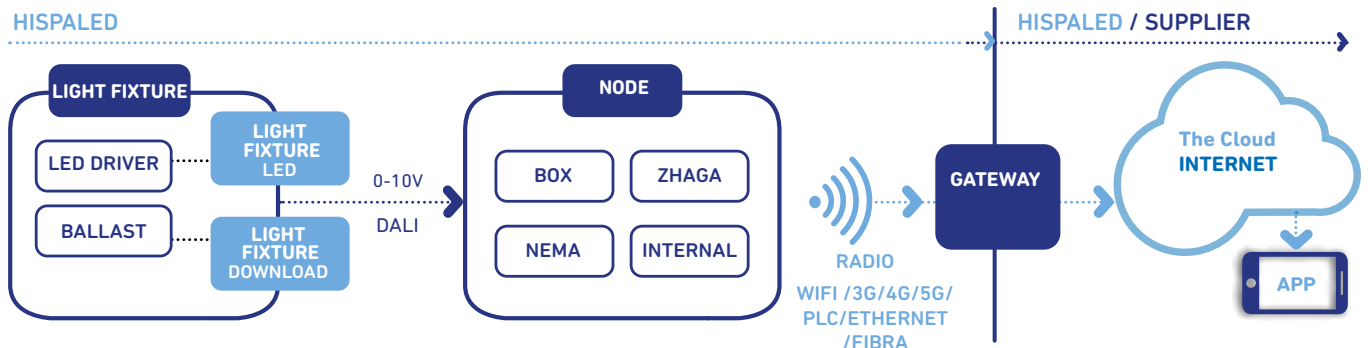

La telegestión de puntos de luz mediante nodos es una tecnología avanzada que permite el control, supervisión, monitorización y gestión remota de sistemas de iluminación pública. A través de nodos de radiofrecuencia, como los basados en tecnologías LoRa (Long Range) y NarrowBand-IoT (NB-IoT), es posible actuar sobre cada punto de luz de manera eficiente y en tiempo real.

Este enfoque no solo mejora la eficiencia energética y reduce los costos operativos, sino que también facilita la implementación de soluciones inteligentes en el ámbito de las ciudades inteligentes.

NARROW BAND NODES

Remote management of streetlights via nodes is an advanced technology that enables the remote control, supervision, monitoring and management of public lighting systems. Using radio frequency nodes, such as those based on LoRa (Long Range) and NarrowBand-IoT (NB-IoT) technologies, it is possible to control each streetlight efficiently and in real time.

This approach not only improves energy efficiency and reduces operating costs, but also facilitates the implementation of smart solutions in the context of smart cities.

RADIO FRECUENCIA NODES (LoRa)

Remote management of street lights via nodes is an advanced technology that enables the control, supervision, monitoring and remote management of public lighting systems. Using radio frequency nodes, such as those based on LoRa (Long Range) and NarrowBand-IoT (NB-IoT) technologies, it is possible to monitor and control each street light efficiently and in real time.

This approach not only improves energy efficiency and reduces operating costs, but also facilitates the implementation of smart solutions in the context of smart cities.

Both LoRa and Narrowband-IoT offer efficient solutions for IoT connectivity, each with specific advantages depending on the project's requirements. LoRa excels in terms of range and energy efficiency for rural environments, whilst Narrowband-IoT provides robust coverage in urban areas. The right choice depends on striking the right balance between range, energy consumption and communication volume.

NODES THAT CAN BE INTEGRATED INTO ANY LIGHTING SYSTEM



NEMA EXTERNAL NODE

The RFLight₂ NEMA external node is available in 5-pin and 7-pin versions. This device complies with the ANSI C136.41 standard and is widely accepted due to its compatibility with photocell-type dimmers, which have been in widespread use around the world for decades. This makes it one of the most common formats currently available.



ZHAGA EXTERNAL NODE

The RFLight₂ ZHAGA external node, as specified in Book 18, is the most up-to-date compatible format on the market, and is arguably the most widely used in newly manufactured luminaires, owing to its simplicity and its design specifically tailored for the control of lighting equipment.

INTEGRATION OF NODES INTO LIGHT FIXTURES

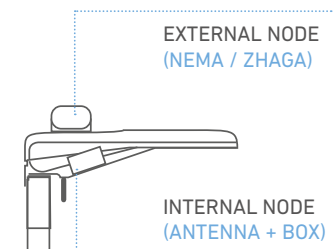

BOX EXTERNAL NODE

The RFLight₂ external node in a box format can be installed in any streetlight on the market. It is mounted on the streetlight bracket and allows the power supply to be routed inside the luminaire, even if the luminaire does not have a NEMA or ZHAGA socket.



INTERNAL NODE

The RFLight₂ internal node is the compact version designed to be installed inside the luminaire. It is powered directly by a 12–24 V DC supply. As this is a radio system, an antenna must be installed on the luminaire.



VERA® LIGHT FIXTURE
Manufactured in-house

HIGH-QUALITY LIGHTING CONTROLLER FOR OUTDOOR LIGHTING

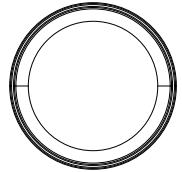
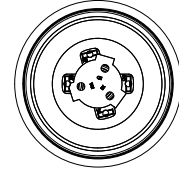
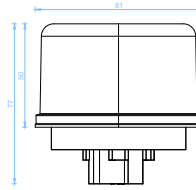
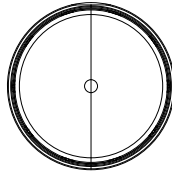
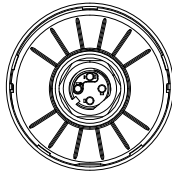
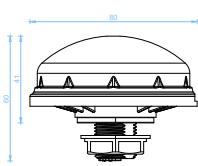

ZHAGA NODE

NEMA NODE



Sports areas



Lighting of monuments



Stations and car parks



Tunnels



Logistics hubs and industrial estates



Parks, and monumental sites



ADVANTAGES

✓ ENERGY EFFICIENCY

By enabling individual control of each light point, remote management systems reduce energy consumption by adapting the lighting to actual needs.

✓ REDUCTION IN OPERATING COSTS

The ability to monitor the status of each light point in real time reduces the need for preventive maintenance and facilitates the detection and repair of faults, thereby lowering operating and maintenance costs.

✓ FLEXIBILITY AND SCALABILITY

The implementation of LoRa and NB-IoT nodes allows the system to be scaled easily, by adding new light points or integrating other IoT applications into the same communication infrastructure.

✓ IMPROVED SAFETY AND SERVICE QUALITY

With remote management, it is possible to ensure adequate lighting at all times, improving public safety and the quality of service provided to citizens.

✓ MONITORIZACIÓN Y ANÁLISIS DE DATOS

These systems enable the collection of operational data that can be analysed to optimise the performance of the lighting system, identify consumption patterns and anticipate future needs.

STREET LIGHTING CONTROLLER WITH LORA PROTOCOL AND ZHAGA AND NEMA CONNECTIONS FOR DALI2 / D4i / 1-10V LUMINAIRES

Daily programming of lighting curves
Configurable up to 32 annual programmes
Curves with up to 5 steps
Individual control of light points
Remote monitoring of DALI2 / D4i driver electrical parameters (luminaire power, line voltage , current, energy consumption, power factor, active power, luminaire operating time counter)
Standalone operation with high-precision internal RTC
Standard, open communication protocol based on LwM2M / MQTT
Alarm monitoring on DALI2 / D4i models: <ul style="list-style-type: none"> • Voltage thresholds • Current thresholds • Detection of faults in the DALI2 / D4i driver or the luminaire • Detection of device faults
Plug&Play

TECHNICAL SPECIFICATIONS

CONNECTIVITY

- Mesh network communication using LoRa technology
- Multi-band. Global coverage

AUTOMATIC GPS POSITIONING

- GPS sensor (optional)
- Integrated antenna
- Supports Glonass, BeiDou, Galileo and QZSS

INTEGRATION WITH CLOUD PLATFORM

- Requires an open gateway for communication with the cloud
- Integrated with Hispaled's RfLight2 platform
- On request, integration with other platforms is possible (AWS IoT, Azure, FIWARE...)

OTRAS CARACTERÍSTICAS

- Supply voltage:
 - Zhaga: 24 V DC
 - NEMA: 220 V AC
- Standby power consumption: 0.5 W
- Maximum power consumption: 3 W
- Power consumption: 0.5W @ 24V (3W max)
- Remote firmware update (OTA)
- Operating temperature range: -20°C to +75°C
- Protection rating: IP66 IK09
- Assembly: NEMA / Zhaga Book 18

CERTIFICATIONS

- CE, RoHS

HIGH-QUALITY LIGHTING CONTROLLER FOR OUTDOOR LIGHTING

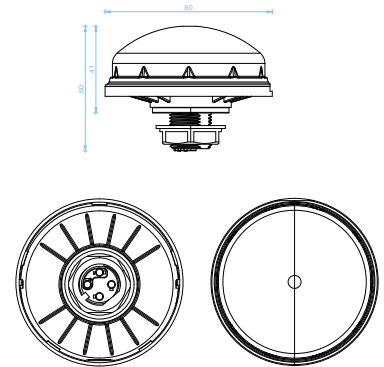

ZHAGA NODE



Sports areas



Lighting of monuments



Stations and car parks



Tunnels



Logistics hubs and industrial estates



Parks, and monumental sites



ADVANTAGES

✓ ENERGY EFFICIENCY

By enabling individual control of each light point, remote management systems reduce energy consumption by adapting the lighting to actual needs.

✓ REDUCTION IN OPERATING COSTS

The ability to monitor the status of each light point in real time reduces the need for preventive maintenance and facilitates the detection and repair of faults, thereby lowering operating and maintenance costs.

✓ FLEXIBILITY AND SCALABILITY

The implementation of LoRa and NB-IoT nodes allows the system to be scaled easily, by adding new light points or integrating other IoT applications into the same communication infrastructure.

✓ IMPROVED SAFETY AND SERVICE QUALITY

With remote management, it is possible to ensure adequate lighting at all times, improving public safety and the quality of service provided to citizens.

✓ DATA MONITORING AND ANALYSIS

These systems enable the collection of operational data that can be analysed to optimise the performance of the lighting system, identify consumption patterns and anticipate future needs.

NARROW-BAND IoT CONNECTIVITY NODES

STREET LIGHTING CONTROLLER WITH NB-IoT OR LTE PROTOCOLS AND ZHAGA CONNECTIVITY FOR DALI2 / D4I LUMINAIRES

Management of multiple DALI2 drivers using the same wireless controller
Daily programming of lighting curves
Configurable with up to 16 annual programmes
Curves with up to 5 steps
Individual control of light points
Remote monitoring of the DALI2 driver's electrical parameters (luminaire power, line voltage, current, energy consumption, power factor, active power, luminaire operating time counter)
Standalone operation with high-precision internal RTC
Standard, open communication protocol based on LwM2M
Alarm monitoring: <ul style="list-style-type: none">• voltage thresholds• current thresholds• detection of DALI2 driver or luminaire faults• device fault detection
Plug&Play. No additional gateways required
Real-time operation and control

TECHNICAL SPECIFICATIONS

IoT CONNECTIVITY

- GSM communication using the NB-IoT protocol (LTE Cat. NB1/2) or LTE Cat. M1
- Multi-band. Global coverage.
- Integrated antenna
- Traditional SIM or eSIM
 - 4FF or MFF2 format with eUICC
- Management of the network operator profile to be used (*)
(*) Requires a model with eSIM and operator support to enable management under the BIP protocol.

AUTOMATIC GPS POSITIONING

- GPS sensor (optional)
- Integrated antenna
- Supports Glonass, BeiDou, Galileo and QZSS

INTEGRATION WITH CLOUD PLATFORM

- LwM2M protocol to minimise data consumption over the GSM network, in accordance with the OMA SpecWorks LightweightM2M specification.
- Integrated with Hispaled's RfLight2 platform
- On request, possibility of integration with other platforms (AWS IoT, Azure, FIWARE...)

OTHER FEATURES

- Supply voltage: 24V (17V to 28V)
- Power consumption: 0.5W @ 24V (3W max)
- Remote firmware update (OTA)
- Operating temperature range: -20°C to +75°C
- Protection rating: IP66 IK09
- Dimensions: 80x60
- Form factor: Zhaga Book 18

CERTIFICATIONS

- CE, RoHS
- Modem certified by various companies in Europe, America and China

Murcia City Council, Murcia.Alumbrado
RFLight2 lighting by Hispaled



Murcia City Council, Murcia.Alumbrado
RFLight2 lighting by Hispaled

Hispaled's Zhaga RFLight2 node



RFLight₂ A different city



 **hispaLed**
A different vision

SPAIN

HISPALED
MADRID / GALICIA

BOLIVIA

LA PAZ
DELEGATION

COLOMBIA

BOGOTÁ
DELEGATION

MOROCCO

CASABLANCA
DELEGATION

RRSS

