

INTEGRAL MANAGEMENT OF STREET LIGHTING
LIGHTING MANAGEMENT
EQUIPMENT (LME)

MONITORING AND CONTROL OF COMMAND CENTRES



HISPALED's RFLight₂ is one of the most advanced remote management systems for street lighting on the market. RFLight₂ Web allows both the luminaires and the control centres of any installation to be managed via a simple and intuitive interface. This ensures that resources are utilised to the full in an efficient manner, maintenance costs are reduced, and a higher quality of lighting is guaranteed across the municipality, with individualised control of light points and electrical panels.

SYSTEM
RFLIGHT₂

- > RFLight₂ Node Lighting nodes
- > LME RFLight₂ Lighting Management Equipment (LME)
- > RFLight₂ Gateway Gateway
- > RFLight₂ Geo Installation and inventory app
- > RFLight₂ Web Web lighting management platform

RFLIGHT₂ ARCHITECTURE

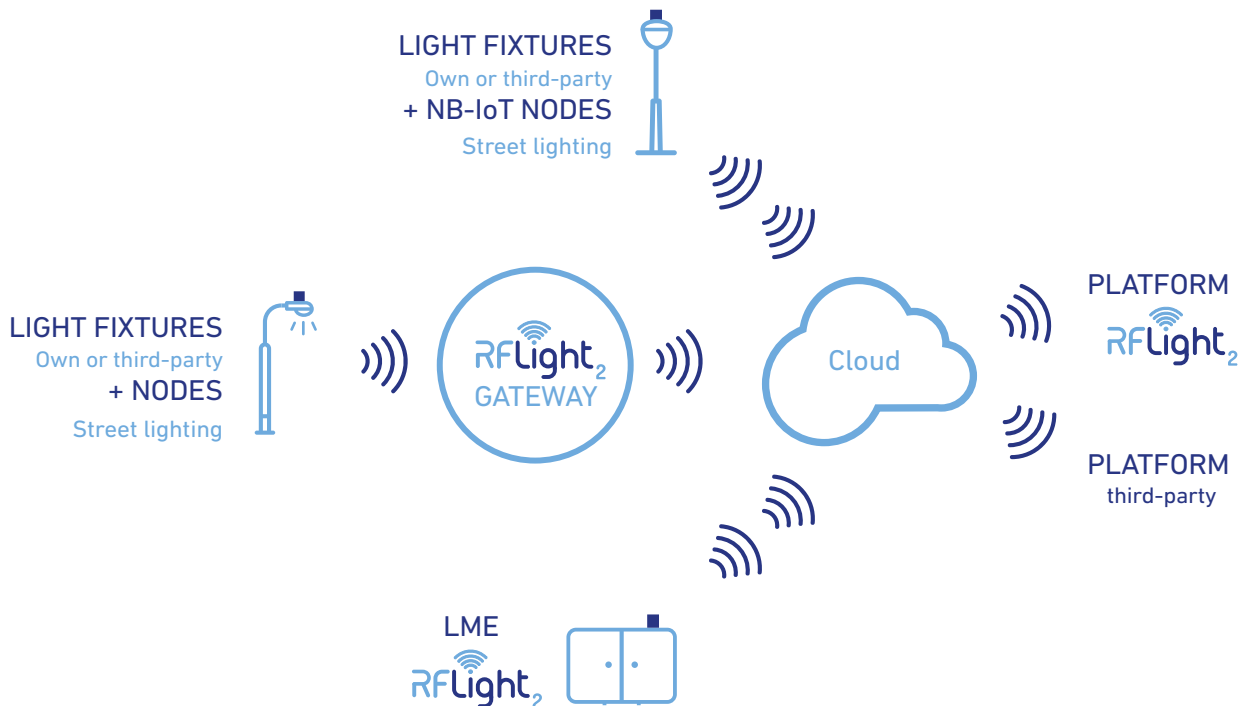

RFLight₂ enables the remote management of lighting fixtures from both HISPALED and other manufacturers. Our open system can be integrated into any web-based lighting management platform.

RFLight₂ enables remote management of control centres and luminaires, whether from HISPALED or other manufacturers, and integrates with any web platform – whether proprietary or third-party – from which to operate lighting management equipment and individual luminaires, reporting information and enabling comprehensive management and control of the lighting system.



LIGHTING MANAGEMENT EQUIPMENT (LME)

RFLIGHT₂ LIGHTING MANAGEMENT EQUIPMENT (LME): CUSTOMIZED SOLUTIONS



TECHNICAL SPECIFICATIONS OF THE RFLIGHT₂ LIGHTING MANAGEMENT EQUIPMENT (LME):

The RFLight₂ Lighting Management Equipment (LME) is an advanced management and control solution designed to effectively monitor and operate lighting systems in urban, suburban and rural environments.

This equipment enables the remote monitoring and control of electrical lines and circuits using various technologies, such as GPRS, Wi-Fi, Ethernet and Bluetooth, thereby ensuring the efficient management of street lighting. Furthermore, it is capable of managing lines and circuits intelligently, taking proactive action based on usage patterns, weather conditions or pre-scheduled events.

It provides advanced data analysis tools that enable the identification of trends, consumption patterns and areas for improvement within the street lighting system.

Finally, it contributes to energy savings and efficiency by enabling the scheduling of automatic switching on and off, as well as the adjustment of light intensity according to actual lighting requirements.

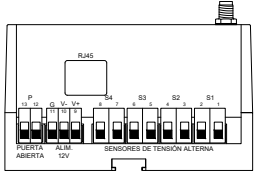
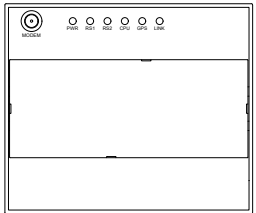
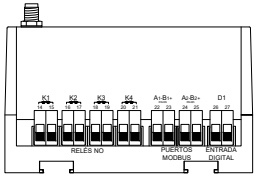
<ul style="list-style-type: none"> • 4 AC voltage sensors 	
<ul style="list-style-type: none"> • 4 NO relay outputs 	
<ul style="list-style-type: none"> • 2 digital inputs 	
<ul style="list-style-type: none"> • 2 RS485 communication ports 	
<ul style="list-style-type: none"> • 1 RJ45 Ethernet port 	
<ul style="list-style-type: none"> • 1 female SMA port 	
<ul style="list-style-type: none"> • Connectivity via: <ul style="list-style-type: none"> • Ethernet – 100 Mbps • WiFi 4 – 600 Mbps – 2,4/5 GHz • Bluetooth 5.2 – 50Mbps – 2,4GHz • GPRS/3G/4G/NB/CAT-M – 900/1.800 MHz 	
<ul style="list-style-type: none"> • Direct-reading network analyser (up to 65 A) and direct measurement via current transformers 	
<ul style="list-style-type: none"> • 12V DC power supply 	

WIRING DIAGRAMS

Lighting Management System (LMS) + Power Supply + Network Analyser + Contactors

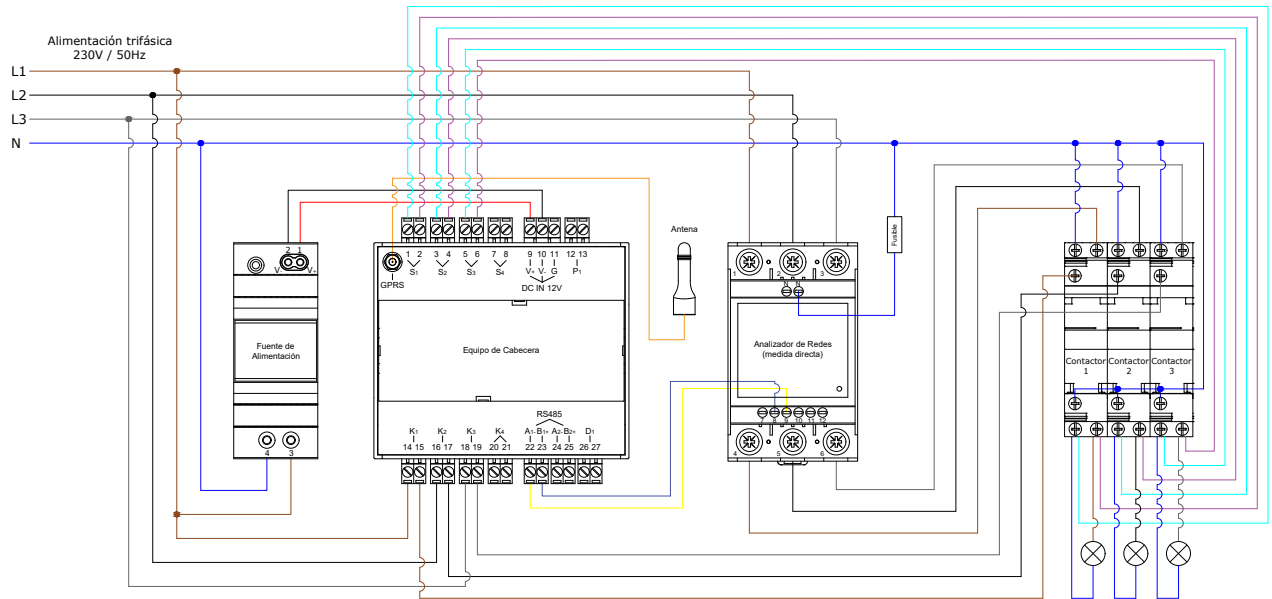

HARDWARE LIGHTING MANAGEMENT EQUIPMENT (LME)

Electrical parameters

Power supply	12 \pm 2 Vdc
Standby power consumption	3W
Input protection	With a 2A, 32V medium-type blade fuse
Reverse polarity protection	With a fuse and Schottky diode
Electrical protection	Class II

AC voltage detection inputs

Absence thresholds	$U_a < 92 \text{ Vac}$
Detection thresholds	$U_d > 146 \text{ Vac}$
Maximum operating insulation voltage	630 Vpk
Overvoltage peak	6.000 Vpk
Insulation	Optoelectronic up to 3,750 Vrms for 1 min
Input protection	Via 510 Vpk varistor (up to 320 VACrms), energy 92 J, 3.5 kA

Relay outputs

Maximum current per contact	5A
Operating voltage	250Vac y 30Vdc
Input protection	430Vpk (up to 275 VAC rms), energy 40 J, 1.75 kA
Type	NO

RS485 communications

Communication mode	Half-duplex - 2-wire
Transmission speed	$T_x \leq 250 \text{ Kbps}$
ESD protection	$\pm 15 \text{ kV}$ on bus pins
TVS protection	7 V/+12 V, 19 A and 600 W for 8/20 μs

Digital tickets

Type of entry	Potential-free
---------------	----------------

Mechanical parameters

IP	20
Operating temperature	-20°C to 65°C
Dimensions	107x90x63mm
Weight	314g

PROGRAMME

- **SWITCHING ON AND OFF**

Allows you to set precise on and off times for electrical circuits and lines, optimising energy consumption and improving operational efficiency.

- **SUNRISE AND SUNSET CALCULATION**

Automatically calculates sunrise and sunset times, allowing lighting to be optimally adjusted according to available natural light.

- **AUTOMATIC SUMMER-WINTER AND WINTER-SUMMER TIME CHANGE**

Automatically adjusts to summer time, eliminating the need for manual intervention and ensuring continuity in the programming of electrical systems.

- **AUTOMATIC ADJUSTMENT BASED ON YOUR LOCATION**

Uses geolocation technology to automatically adjust the time based on the location of the Control Centre, ensuring precise synchronisation with local time.

- **RELAY MANAGEMENT INDEPENDENT OF THE SCHEDULE**

Allows relays to be managed independently of the established schedule, providing greater flexibility and control over the operation of electrical systems.

- **PROFILE AND CALENDAR MANAGEMENT**

Offers the ability to create and manage custom configuration profiles and calendars, adapting to the specific needs of each user and environment.

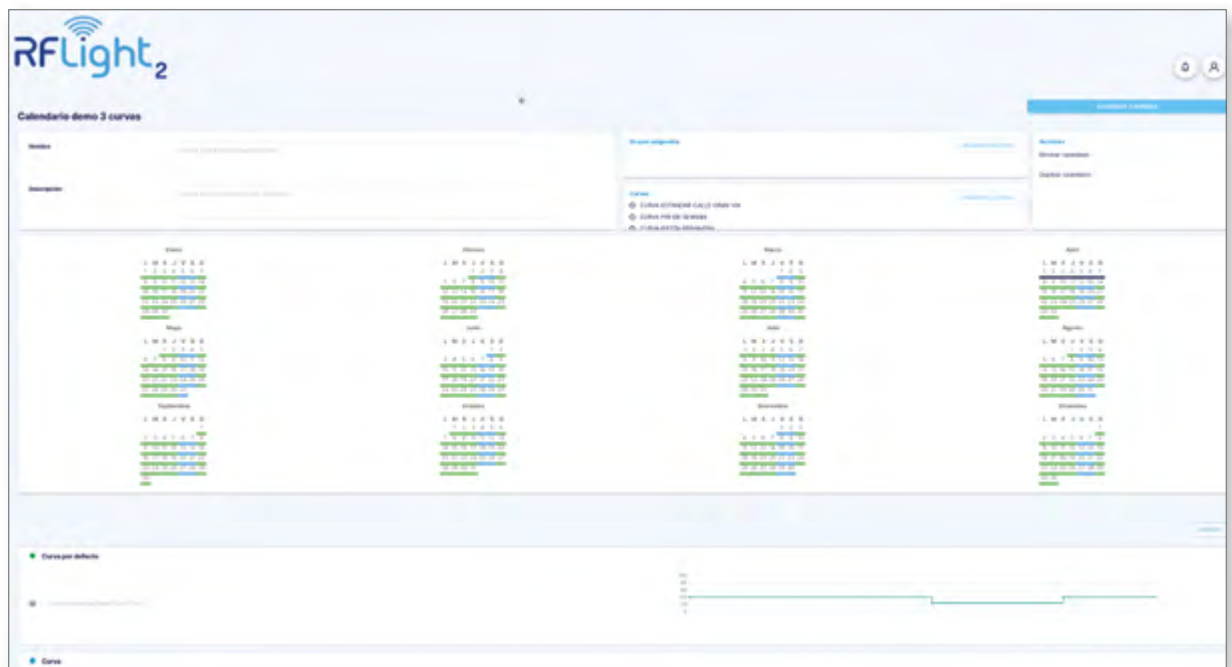

ALARMS

Users have the flexibility to set up alarms and notifications to suit their specific needs.

- **PROGRAMMABLE BASED ON ELECTRICAL PARAMETERS**

It offers the ability to intelligently programme alarms and alerts using the electrical parameters of the power line. This function enables early detection of potential problems and a proactive response to risky situations.

- **PROGRAMMABLE BASED ON EXTERNAL SENSORS**

It can integrate readings from external sensors, such as: temperature, presence and noise sensors, etc. This expands its risk detection and adaptability capabilities, enabling a more comprehensive response to different situations.

ANALYSIS

- **CIRCUIT MONITORING AND CONTROL**

It is capable of monitoring and controlling multiple electrical circuits in real time, allowing users to instantly view the operational status of each one..

- **REAL-TIME CONSUMPTION AND CONSUMPTION HISTORICS**

In addition to providing real-time data, the Command Centre displays consumption histories, enabling comparisons between periods and a deeper understanding of consumption patterns over time.

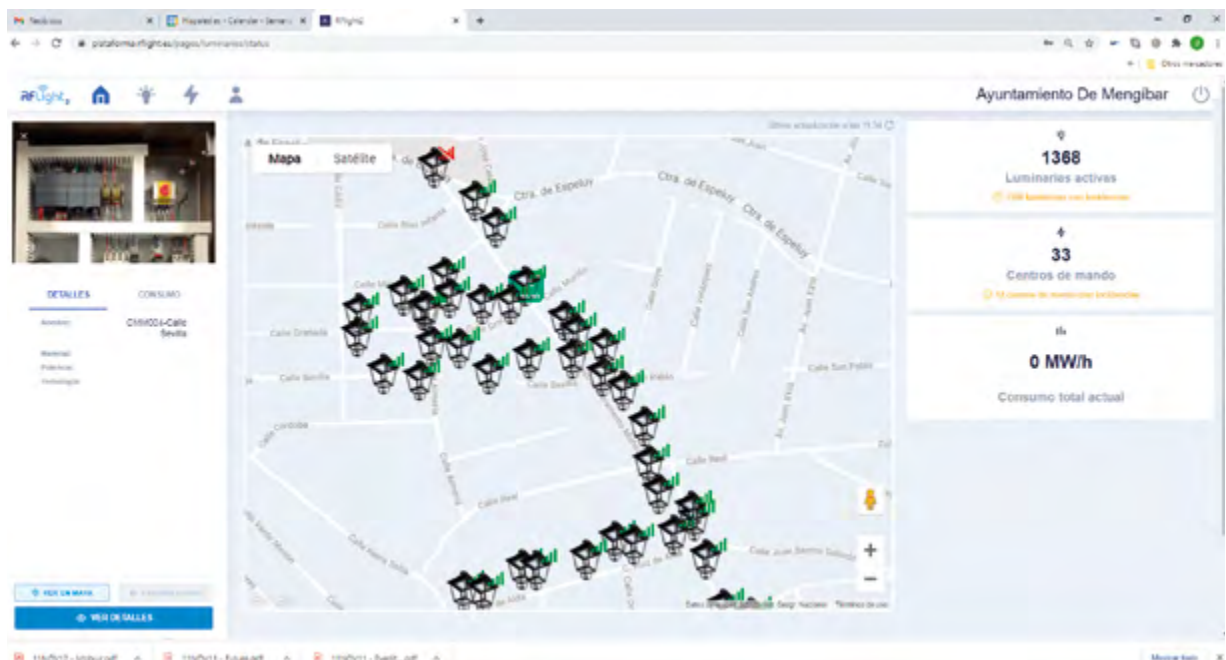

RFLight₂



A different vision

SPAIN
.....
HISPALED
MADRID / GALICIA

BOLIVIA
.....
LA PAZ
DELEGATION

COLOMBIA
.....
BOGOTÁ
DELEGATION

MOROCCO
.....
CASABLANCA
DELEGATION

RRSS
.....
  