



A different vision

CATALOGUE OF PRODUCTS

LIGHTING
FIXTURES

ENG_v26

HISPALED: LEADING SPANISH COMPANY IN LED TECHNOLOGY AND CONNECTIVITY SOLUTIONS FOR SMART CITIES

Since 2009 we design, manufacture and commercialize luminaires with LED technology for different applications: Public Lighting, Industrial, Horticulture, etc. as well as intelligent control systems for our products.

MISSION

To be a reference in the market and recognized as an innovative, professional and sustainable company. A different vision of how to do things, with the best product and service, economic efficiency and accompaniment to young people in vulnerable situations.

VISION

Business is a powerful tool for change in society. It is possible to be competitive and socially responsible. We take care of the relationships within the company, with customers and suppliers to make work more humane and rewarding.

VALUES

- Personalized attention.
- Professionalism.
- Quality.
- Innovation.
- Sincerity and transparency.
- Ethics with values.
- Identification and empathy.
- Environmental sustainability.

HISPALED: A DIFFERENT VISION, A SOCIAL VISION

HISPALED is a business project linked to the commitment to the social and labor insertion of young people in vulnerable situations. We are the first manufacturer of LED technology solutions in Spain and the first industrial company in the Community of Madrid with the qualification of INSERTION COMPANY, under Law 44/2007.



Madrid: street lighting



Almeria: horticulture lighting



Madrid: socio-occupational insertion workshop



STUDY



CONSULTING



DESIGN



MANUFACTURING



HOMOLOGATION



INSTALLATION



MAINTENANCE



WARRANTY

HispaLED offers an integral lighting solution based on LED technology.

HispaLED is a 100% Spanish company pioneer in the development of remote management solutions for public lighting. We accompany our customers in the supply and preparation of offers. We are proud to be the first company worldwide to develop a street lighting system based on LoRa technology with meshed network topology, called LoRaMesh.

HISPALED: A DIFFERENT VISION, A GLOBAL VISION

WE ARE MANUFACTURERS:

Our factories in Ordes (La Coruña) and Madrid - Vicálvaro, have the most advanced technical resources and the necessary technology to respond to an increasingly complex and demanding global market. HISPALED has its own hardware and assembly departments, which ensure the best product quality and short delivery times.



MADRID
Offices/ Factory
CORUÑA
Factory

600

Townships
in Spain

60

Lighting
Concessions

150.000

Tn of Co₂
not emitted

More than
350.000

luminaires
manufactured
for municipalities
around the world

Exports to EUROPE, LATAM and AFRICA

We have implemented important public lighting projects in Latin America (Chile, Colombia, Peru...), Europe (United Kingdom...), Africa (Morocco...) and Asia (Lebanon...).



A different vision

The widest range of solutions for street lighting

With the best COMPONENTS:



LEDS



DRIVERS



LENS



VIALS

VERA S/M/X/XL

- VRS 10W-60 W
- VRM 10W-100 W
- VRX 40W-160 W
- VRXL 10W-220 W

TURKANA S/M

- TKS 10W-100 W
- TKM 40W-200 W

Objective spaces:
STREETS
ROADS
URBAN SPACES

Heights:
4-15m

Interdistances:
10-50m

Powers:
10W-200W



ORNAMENTALS

SENDA

- SNS 10W-60W
- SNM 10W-100W

STYLO

- STS 10W-60W
- STM 10W-100W

VILLA S/M/X

- VL 10W-80W

FERNANDINO

- FN 10W-80W

Objective spaces:
URBAN SPACES
PARKS
PEDESTRIAN ZONES

Heights:
4-10m

Interdistances:
10-40m

Powers:
10W-100W





RETROFIT

RETROFIT
RT 10W-80W

Objective spaces:
URBAN SPACES
PARKS
PEDESTRIAN ZONES

Heights:
4-10m

Interdistances:
10-40m

Powers:
10W-80W



PROJECTORS

MERCURY
MRC 100W-1200 W

PORTO
PRTS 10W-200W
PRTS 140W-400W

PRISMA
PRM 60W-1500W

Objective spaces:
SPORTS COURTS
FACADES
ROAD INTERSECTIONS

Heights:
4-30m

Interdistances:
-

Powers:
10W-1500W



INDUSTRIALS

FABRIK
FBK 60W-250W

LISA
LSA 50W-200W

Objective spaces:
BUILDINGS
INDUSTRIAL
SPORTS TRACKS

Heights:
4-20m

Interdistances:
-

Powers:
50W-250W



VIALS



VERA S



Roads/
Urban roads



Residential
streets



Parking



Logistics
platforms



Stations



Bicycle lanes

VERAHISPALED





New generation of street lighting with an unbeatable price/performance ratio

COST EFFECTIVENESS AND EFFICIENCY

The Vera series is a compact luminaire, with a simplified line, ideal for residential streets and urban roads of low to moderate speed.

Lighting solution with maximum profitability and fast amortization. It allows to reduce energy costs and enjoy all the advantages of LED lighting, with a very low investment.



TECHNICAL DATA SHEET

ENEC 01; CE; RoHS; EN 60598-1:2009 + A1:2009; EN 60598-2-3:2003 + Corr:2005 + A1:2011; EN 62031:2009 + A1:2011; EN 62471:2008; IES LM-80; EN 61347-1:2008; EN 61347-2-13:2006; EN 55015:2006 + A1:2007 + A2:2009; EN 61547:2009; EN 61000-3-2:2006 + A1:2009 + A2:2009; EN 61000-3-3:2008; EN 61000-4-2,3,4,5,6,8,11; UL 8750; IEC 60598-1:2008; IEC 60598-2-3:2002; IEC 62031:2008; IEC 62471:2008; IES LM-80; IEC 61347-1:2008; IEC 61347-2-13:2006; IEC 55015:2006; + A1:2007 + A2:2009; IEC 61547:2009; IEC 61000-3:2006; A1:2009 + A2:2009; IEC 61000-3-3:2008; IEC 61000-4-2,3,4,5,6,8,11; UL 8750;

The Vera Series offers solutions of up to 60W of power, guaranteeing optimum results in all types of streets and urban roads with minimum investment costs. Its die-cast aluminum structure with flat cover, and the arrangement of independent spaces for optical block and driver, provide excellent heat dissipation, guaranteeing a useful life of more than 100,000 hours of operation.

It is suitable for post-top or side-entry mounting, allowing tilt adjustment to adapt perfectly to the lighting needs of each track. Its lightweight appearance and tool-free opening makes it easy to install at height for the installer, with the option of an electrical disconnection system during opening, which offers maximum safety when handled. This road luminaire offers multiple lighting packages, with a wide range of photometric distributions and operating currents.

It allows plug & play installation of NEMA / ZHAGA socket compatible devices, ensuring easy integration with point-to-point remote management systems.

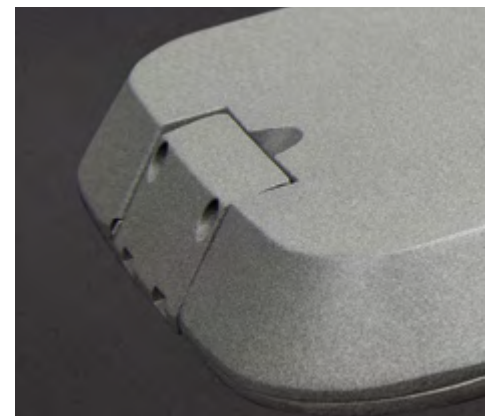

TECHNICAL DATA SHEET

VERA S

VERA*

| Structure | Aluminum injection |
|-----------------------|---|
| Diffuser | Tempered glass/polycarbonate |
| Dimensions and weight | 513x225x110 mm / 3.3 Kg |
| Anchoring systems | Post-top and side Ø up to 65 mm with 0 to 90° rotation |
| Degree of protection | IP66, IK08 (IK10 optional) |
| Warranty | 5/7/10 years |
| Certification | CE; RoHS |
| Safety class | I/II |
| Opening | Tool-free, with optional electrical disconnection. |

OPTIONAL CONTROL SYSTEMS

Programmable regulation of up to 8 levels
 Time programming module
 (35 programs | reprogrammable from CM | winter-summer distinction)
 Point to point remote management RFLight₂
 DALI2/D4i, 1 -10V
 CLO (constant light level)
 Dimming at the head-end
 Control line dimming
 Photocell
 Socket NEMA 7 / Zhaga book 18
 Others: PLC, GPRS, 3G, NFC, NFC, Bluetooth, Narrow Band 5G

FEATURES*

| | |
|-------------------|--|
| Power | 10W-60W |
| Efficiency lm/W | Up to 170 lm/W |
| Input voltage | 90-305 V / ~ 50-60Hz (depending on model) |
| Power supply | PF > 0.95, Efficiency > 88% (depending on model) |
| Lifetime | >100,000 hours (L90B10) |
| LED Type | Cree®, Nichia®, Osram® |
| Color temperature | 1,800 K - 6,000 K / PC-Amber |
| Minimum CRI | 70/80 |
| FHS | 0% |

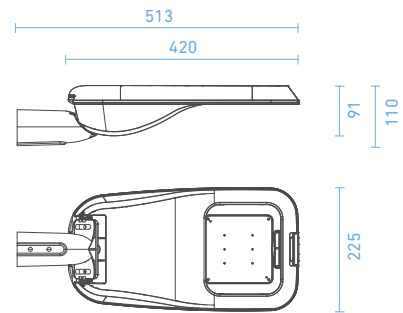

VERSIONS*

| | ECO | STANDARD | PREMIUM | |
|-------------------------------|-----|----------|---------|---|
| OVERVOLTAGE PROTECTION | | | | ● Included ○ Optional ✕ Not available |
| 10 kV (en f. alim.) | ● | ✕ | ✕ | |
| 10 kV (SPD ext.) | ✕ | ● | ● | |
| 20 kV (SPD ext.) | ✕ | ○ | ○ | |
| REGULATION | | | | |
| 8 Levels | ● | ● | ✕ | |
| MPH (reprogrammable) | ✕ | ○ | ● | |
| OPERATING CURRENT | | | | |
| 500 mA | ○ | ○ | ● | |
| 700 mA | ○ | ● | ○ | |
| 1000 mA | ● | ○ | ○ | |

OPTICAL BLOCK

(Consult for more optical options)



| ROAD I | ROAD II | ROAD III | ROAD IV | URBAN 360 |
|--|--|---|---|--|
| Recommended distribution on tracks with extreme spacings up to 6 times the pole height | Recommended layout for roadways with a track width similar to the height of the pole | Recommended layout for roadways with up to two lanes with spacings up to 4 times the pole height. | Recommended distribution on tracks with high clearances of up to 5 times the height of the pole | Recommended distribution for medium-height omnidirectional lighting, such as parks and squares |

* Specifications are subject to change



GALICIA
LARACHA CITY COUNCIL (A CORUÑA)
Installation of Hispaled's VERA luminaires.

VIALS



VERA M



Roads/
Urban roads



Residential
streets



Parking



Logistics
platforms



Stations



Bicycle lanes

VERAMHISPALED





New generation of street lighting with an unbeatable price/performance ratio

PROFITABILITY AND EFFICIENCY

The Vera series is a compact luminaire, with a simplified line, ideal for residential streets and urban roads of low to moderate speed.

Lighting solution with maximum profitability and fast amortization. It allows to reduce energy costs and enjoy all the advantages of LED lighting, with a very low investment.

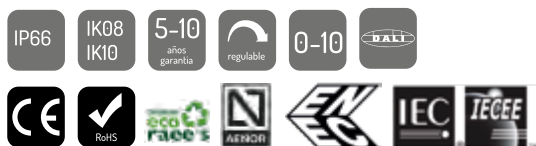

TECHNICAL DATA SHEET

ENEC 01; CE, RoHS; EN 60598-1:2009 + A1:2009; EN 60598-2-3:2003 + Corr:2005 + A1:2011; EN 62031:2009 + A1:2011; EN 62471:2008; IES LM-80; EN 61347-1:2008; EN 61347-2-13:2006; EN 55015:2006 + A1:2007 + A2:2009; EN 61547:2009; EN 61000-3-2:2006 + A1:2009 + A2:2009; EN 61000-3-3:2008; EN 61000-4-2,3,4,5,6,8,11; UL 8750; IEC 60598-1:2008; IEC 60598-2-3:2002; IEC 62031:2008; IEC 62471:2008; IES LM-80; IEC 61347-1:2008; IEC 61347-2-13:2006; IEC 55015:2006; + A1:2007 + A2:2009; IEC 61547:2009; IEC 61000-3:2006; A1:2009 + A2:2009; IEC 61000-3-3:2008; IEC 6100-4-2,3,4,5,6,8,11; UL 8750;

The Vera M Series offers solutions of up to 100W of power, guaranteeing optimal results in all types of streets and urban roads with minimum investment costs. Its die-cast aluminum structure with flat cover, and the arrangement of independent spaces for optical block and driver, provide excellent heat dissipation, guaranteeing a useful life of more than 100,000 hours of operation.

It is suitable for post-top or side-entry mounting, allowing tilt adjustment to adapt perfectly to the lighting needs of each track. Its lightweight appearance and tool-free opening makes it easy to install at height for the installer, with the option of an electrical disconnection system during opening, which offers maximum safety when handled. This road luminaire offers multiple lighting packages, with a wide range of photometric distributions and operating currents.

It allows plug & play installation of NEMA / ZHAGA socket compatible devices, ensuring easy integration with point-to-point remote management systems.

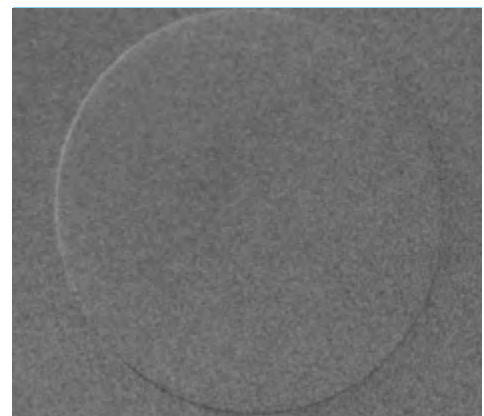
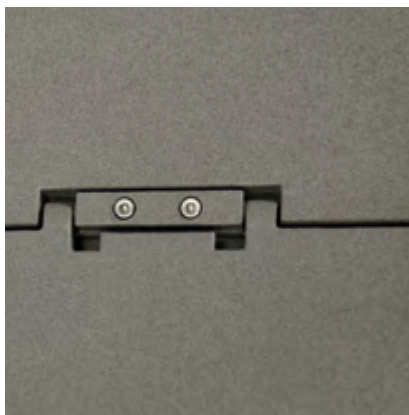

TECHNICAL DATA SHEET

VERA M

VERA*

| | SPECIFICATIONS |
|-----------------------|---|
| Structure | Aluminum injection |
| Diffuser | Tempered glass/polycarbonate |
| Dimensions and weight | 647x255x119 mm / 5.9 kg |
| Anchoring systems | Post-top and side Ø up to 65 mm with 0 to 90° rotation |
| Degree of protection | IP66, IK08 (IK10 optional) |
| Warranty | 5/7/10 years |
| Certification | CE; RoHS |
| Safety class | I/II |
| Opening | Tool-free, with optional electrical disconnection. |

OPTIONAL CONTROL SYSTEMS

Programmable regulation of up to 8 levels
 Time programming module
 (35 programs | reprogrammable from CM | winter-summer distinction)
 Point to point remote management RFLight2
 DALI2/D4i, 1 -10V
 CLO (constant light level)
 Dimming at the head-end
 Control line dimming
 Photocell
 Socket NEMA 7 / Zhaga book 18
 Others: PLC, GPRS, 3G, NFC, NFC, Bluetooth, Narrow Band 5G

FEATURES*

| | |
|-------------------|--|
| Power | 10W-100W |
| Efficiency lm/W | Up to 170 lm/W |
| Input voltage | 90-305 V / ~ 50-60Hz (depending on model) |
| Power supply | PF > 0.95, Efficiency > 88% (depending on model) |
| Lifetime | >100,000 hours (L90B10) |
| LED Type | Cree®, Nichia®, Osram® |
| Color temperature | 1,800 K - 6,000 K / PC-Amber |
| Minimum CRI | 70/80 |
| FHS | 0% |

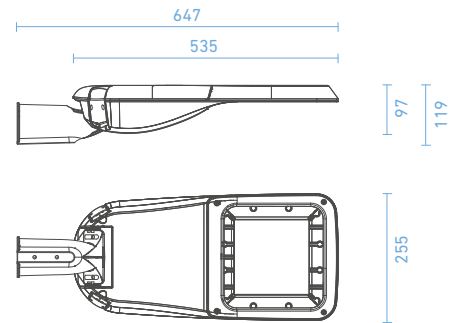

VERSIONS*

| | ECO | STANDARD | PREMIUM | |
|-------------------------------|-----|----------|---------|---|
| OVERVOLTAGE PROTECTION | | | | ● Included ○ Optional ✕ Not available |
| 10 kV (en f. alim.) | ● | ✕ | ✕ | |
| 10 kV (SPD ext.) | ✕ | ● | ● | |
| 20 kV (SPD ext.) | ✕ | ○ | ○ | |
| REGULATION | | | | |
| 8 Levels | ● | ● | ✕ | |
| MPH (reprogrammable) | ✕ | ○ | ● | |
| OPERATING CURRENT | | | | |
| 500 mA | ○ | ○ | ● | |
| 700 mA | ○ | ● | ○ | |
| 1000 mA | ● | ○ | ○ | |

OPTICAL BLOCK

(Consult for more optical options)



| ROAD I | ROAD II | ROAD III | ROAD IV | URBAN 360 |
|--|--|---|---|--|
| Recommended distribution on tracks with extreme spacings up to 6 times the pole height | Recommended layout for roadways with a track width similar to the height of the height of the pole | Recommended layout for roadways with up to two lanes with spacings up to 4 times the pole height. | Recommended distribution on tracks with high clearances of up to 5 times the height of the pole | Recommended distribution for medium-height omnidirectional lighting, such as parks and squares |

* Specifications are subject to change



ALICANTE
BENIDORM CITY COUNCIL (ALICANTE)
Installation of VERA luminaires of Hispaled

VIALS



VERA X



Roads/
Urban roads



Residential
streets



Parking



Logistics
platforms



Stations



Bicycle lanes

VERAXHISPALED

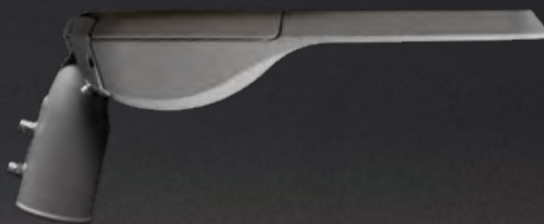



New generation of street lighting with an unbeatable price/performance ratio

PROFITABILITY AND EFFICIENCY

The Vera series is a compact luminaire, with a simplified line, ideal for residential streets and urban roads of low to moderate speed.

Lighting solution with maximum profitability and fast amortization. It allows to reduce energy costs and enjoy all the advantages of LED lighting, with a very low investment.

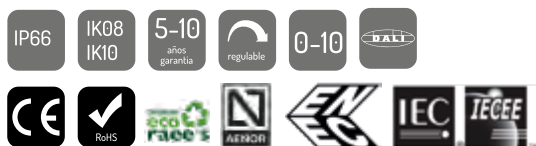

TECHNICAL DATA SHEET

ENEC 01; CE, RoHS; EN 60598-1:2009 + A1:2009; EN 60598-2-3:2003 + Corr:2005 + A1:2011; EN 62031:2009 + A1:2011; EN 62471:2008; IES LM-80; EN 61347-1:2008; EN 61347-2-13:2006; EN 55015:2006 + A1:2007 + A2:2009; EN 61547:2009; EN 61000-3-2:2006 + A1:2009 + A2:2009; EN 61000-3-3:2008; EN 61000-4-2,3,4,5,6,8,11; UL 8750; IEC 60598-1:2008; IEC 60598-2-3:2002; IEC 62031:2008; IEC 62471:2008; IES LM-80; IEC 61347-1:2008; IEC 61347-2-13:2006; IEC 55015:2006; + A1:2007 + A2:2009; IEC 61547:2009; IEC 61000-3:2006; A1:2009 + A2:2009; IEC 61000-3-3:2008; IEC 6100-4-2,3,4,5,6,8,11; UL 8750;

The Vera X Series offers solutions of up to 160W of power, guaranteeing optimal results in all types of streets and urban roads with minimum investment costs. Its die-cast aluminum structure with flat cover, and the arrangement of independent spaces for optical block and driver, provide excellent heat dissipation, guaranteeing a useful life of more than 100,000 hours of operation.

It is suitable for post-top or side-entry mounting, allowing tilt adjustment to adapt perfectly to the lighting needs of each track. Its lightweight appearance and tool-free opening makes it easy to install at height for the installer, with the option of an electrical disconnection system during opening, which offers maximum safety when handled. This road luminaire offers multiple lighting packages, with a wide range of photometric distributions and operating currents.

It allows plug & play installation of NEMA / ZHAGA socket compatible devices, ensuring easy integration with point-to-point remote management systems.

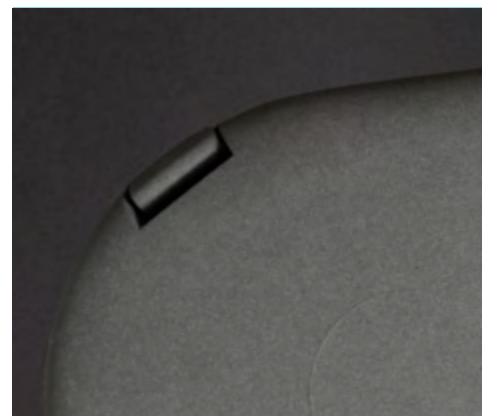
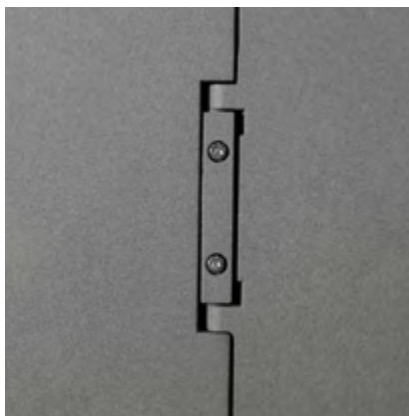

TECHNICAL DATA SHEET

VERA X

VERA*

| Structure | Aluminum injection |
|-----------------------|---|
| Diffuser | Tempered glass/polycarbonate |
| Dimensions and weight | 704x289x113 mm / 7.3 kg |
| Anchoring systems | Post-top and side Ø up to 65 mm with 0 to 90° rotation |
| Degree of protection | IP66, IK08 (IK10 optional) |
| Warranty | 5/7/10 years |
| Certification | CE; RoHS |
| Safety class | I/II |
| Opening | Tool-free, with optional electrical disconnection. |

OPTIONAL CONTROL SYSTEMS

Programmable regulation of up to 8 levels
 Time programming module
 (35 programs | reprogrammable from CM | winter-summer distinction)
 Point to point remote management RFLight₂
 DALI2/D4i, 1 -10V
 CLO (constant light level)
 Dimming at the head-end
 Control line dimming
 Photocell
 Socket NEMA 7 / Zhaga book 18
 Others: PLC, GPRS, 3G, NFC, NFC, Bluetooth, Narrow Band 5G

CHARACTERISTICS*

| | |
|-------------------|--|
| Power | 40W-160W |
| Efficiency lm/W | Up to 170 lm/W |
| Input voltage | 90-305 V / ~ 50-60Hz (depending on model) |
| Power supply | PF > 0.95, Efficiency > 88% (depending on model) |
| Lifetime | >100,000 hours (L90B10) |
| LED Type | Cree®, Nichia®, Osram® |
| Color temperature | 1,800 K - 6,000 K / PC-Amber |
| Minimum CRI | 70/80 |
| FHS | 0% |

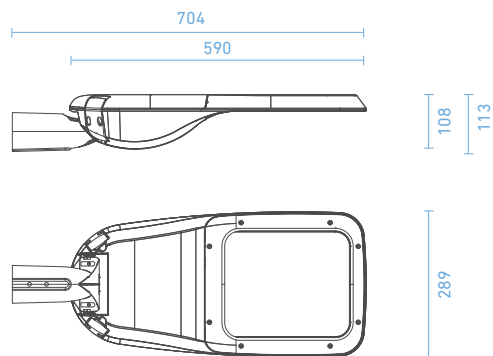

VERSIONS*

| | ECO | STANDARD | PREMIUM | |
|-------------------------------|-----|----------|---------|---|
| OVERVOLTAGE PROTECTION | | | | ● Included ○ Optional ✗ Not available |
| 10 kV (en f. alim.) | ● | ✗ | ✗ | |
| 10 kV (SPD ext.) | ✗ | ● | ● | |
| 20 kV (SPD ext.) | ✗ | ○ | ○ | |
| REGULATION | | | | |
| 8 Levels | ● | ● | ✗ | |
| MPH (reprogrammable) | ✗ | ○ | ● | |
| OPERATING CURRENT | | | | |
| 500 mA | ○ | ○ | ● | |
| 700 mA | ○ | ● | ○ | |
| 1000 mA | ● | ○ | ○ | |

OPTICAL BLOCK

(Consult for more optical options)

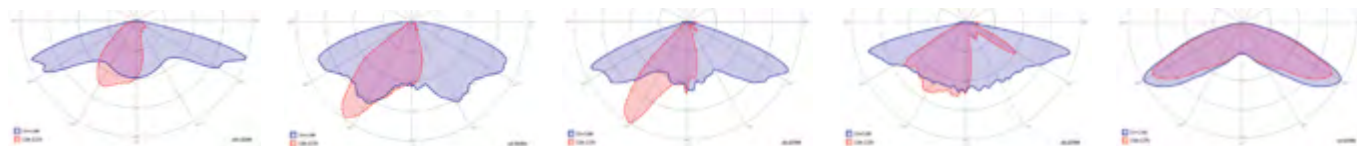

ROAD I

Recommended distribution on tracks with extreme spacings up to 6 times the pole height

ROAD II

Recommended layout for roadways with a track width similar to the height of the pole

ROAD III

Recommended layout for roadways with up to two lanes with spacings up to 4 times the pole height.

ROAD IV

Recommended distribution on tracks with high clearances of up to 5 times the height of the pole

URBAN 360

Recommended distribution for medium-height omnidirectional lighting, such as parks and squares

* Specifications are subject to change



GALICIA
ORDES CITY COUNCIL (A CORUÑA)
Installation of Hispaled's VERA luminaires.

VIALS



VERA XL



Roads/
Urban roads



Residential
streets



Parking



Logistics
platforms



Stations



Bicycle lanes

VERAXLHISPALED

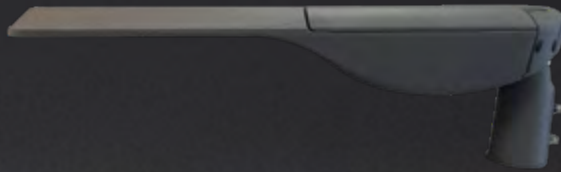



New generation of street lighting with an unbeatable price/performance ratio

PROFITABILITY AND EFFICIENCY

The Vera series is a compact luminaire, with a simplified line, ideal for residential streets and urban roads of low to moderate speed.

Lighting solution with maximum profitability and fast amortization. It allows to reduce energy costs and enjoy all the advantages of LED lighting, with a very low investment.



TECHNICAL DATA SHEET

ENEC 01; CE, RoHS; EN 60598-1:2009 + A1:2009; EN 60598-2-3:2003 + Corr:2005 + A1:2011; EN 62031:2009 + A1:2011; EN 62471:2008; IES LM-80; EN 61347-1:2008; EN 61347-2-13:2006; EN 55015:2006 + A1:2007 + A2:2009; EN 61547:2009; EN 61000-3-2:2006 + A1:2009 + A2:2009; EN 61000-3-3:2008; EN 61000-4-2,3,4,5,6,8,11; UL 8750; IEC 60598-1:2008; IEC 60598-2-3:2002; IEC 62031:2008; IEC 62471:2008; IES LM-80; IEC 61347-1:2008; IEC 61347-2-13:2006; IEC 55015:2006; + A1:2007 + A2:2009; IEC 61547:2009; IEC 61000-3:2006; A1:2009 + A2:2009; IEC 61000-3-3:2008; IEC 6100-4-2,3,4,5,6,8,11; UL 8750;

The Vera XL Series offers solutions of up to 220W of power, guaranteeing optimal results in all types of streets and urban roads with minimum investment costs. Its die-cast aluminum structure with flat cover, and the arrangement of independent spaces for optical block and driver, provide excellent heat dissipation, guaranteeing a useful life of more than 100,000 hours of operation.

It is suitable for post-top or side-entry mounting, allowing tilt adjustment to adapt perfectly to the lighting needs of each track. Its lightweight appearance and tool-free opening makes it easy to install at height for the installer, with the option of an electrical disconnection system during opening, which offers maximum safety when handled. This road luminaire offers multiple lighting packages, with a wide range of photometric distributions and operating currents.

It allows plug & play installation of NEMA / ZHAGA socket compatible devices, ensuring easy integration with point-to-point remote management systems.

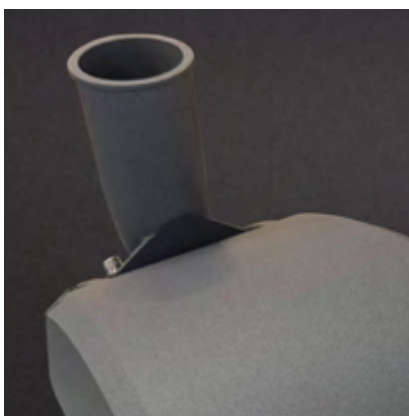
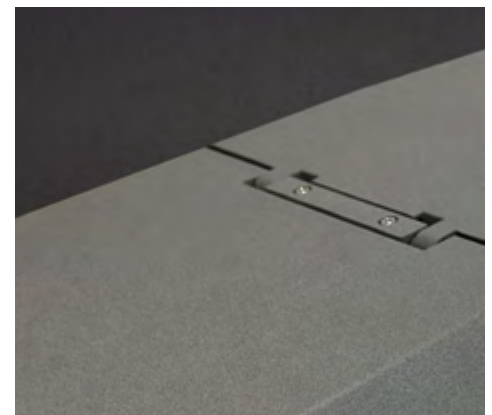

TECHNICAL DATA SHEET

VERA XL

VERA XL*

| Structure | Aluminum injection |
|-----------------------|---|
| Diffuser | Tempered glass/polycarbonate |
| Dimensions and weight | 690x340x113 mm / 9 kg |
| Anchoring systems | Post-top and side Ø up to 65 mm with 0 to 90° rotation |
| Degree of protection | IP66, IK08, IK10 |
| Warranty | 5/7/10 years |
| Certification | CE; RoHS |
| Safety class | I/II |
| Opening | Without tool, with optional electrical disconnect. |

OPTIONAL CONTROL SYSTEMS

Programmable regulation of up to 8 levels
 Time programming module
 (35 programs | reprogrammable from CM | winter-summer distinction)
 Point to point remote management RFLight₂
 DALI2/D4i, 1 -10V
 CLO (constant light level)
 Dimming at the head-end
 Control line dimming
 Photocell
 Socket NEMA 7 / Zhaga book 18
 Others: PLC, GPRS, 3G, NFC, NFC, Bluetooth, Narrow Band 5G

CARACTERÍSTICAS*

| | |
|-------------------|--|
| Power | 80W-220W |
| Efficiency lm/W | Up to 170 lm/W |
| Input voltage | 90-305 V / ~ 50-60Hz (depending on model) |
| Power supply | PF > 0.95, Efficiency > 88% (depending on model) |
| Lifetime | >100,000 hours (L90B10) |
| LED Type | Cree®, Nichia®, Osram® |
| Color temperature | 1,800 K - 6,000 K / PC-Amber |
| Minimum CRI | 70/80 |
| FHS | 0% |

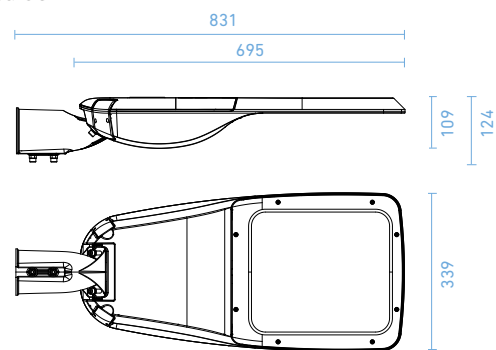

VERSIONS*

| | ECO | STANDARD | PREMIUM | |
|-------------------------------|-----|----------|---------|---|
| OVERVOLTAGE PROTECTION | | | | ● Included ○ Optional ✗ Not available |
| 10 kV (en f. alim.) | ● | ✗ | ✗ | |
| 10 kV (SPD ext.) | ✗ | ● | ● | |
| 20 kV (SPD ext.) | ✗ | ○ | ○ | |
| REGULATION | | | | |
| 8 Levels | ● | ● | ✗ | |
| MPH (reprogrammable) | ✗ | ○ | ● | |
| OPERATING CURRENT | | | | |
| 500 mA | ○ | ○ | ● | |
| 700 mA | ○ | ● | ○ | |
| 1000 mA | ● | ○ | ○ | |

OPTICAL BLOCK

(Consult for more optical options)



| ROAD I | ROAD II | ROAD III | ROAD IV | URBAN 360 |
|--|--|---|---|--|
| Recommended distribution on tracks with extreme spacings up to 6 times the pole height | Recommended layout for roadways with a track width similar to the height of the height of the pole | Recommended layout for roadways with up to two lanes with spacings up to 4 times the pole height. | Recommended distribution on tracks with high clearances of up to 5 times the height of the pole | Recommended distribution for medium-height omnidirectional lighting, such as parks and squares |

* Specifications are subject to change



M40
CITY COUNCIL OF MADRID (MADRID)
Installation of VERA luminaires of Hispaled

VIALS



TURKANA S



Roads/
Urban roads



Streets
residential



Parking



Logistics
platforms



Stations



Bicycle lanes

TURKANASHISPALED





State-of-the-art roadway with high performance and state-of-the-art LED technology

DESIGN AND PERFORMANCE

The Turkana S series is a functional road type luminaire that guarantees maximum performance on all types of roads and highways, both urban and interurban.

Elements such as its excellent design, its high quality finish or the integration of remote management systems with easy connectivity, make it a benchmark in the street lighting market.



TECHNICAL DATA SHEET

ENEC 01; CE, RoHS; EN 60598-1:2009 + A1:2009; EN 60598-2-3:2003 + Corr:2005 + A1:2011; EN 62031:2009 + A1:2011; EN 62471:2008; IES LM-80; EN 61347-1:2008; EN 61347-2-13:2006; EN 55015:2006 + A1:2007 + A2:2009; EN 61547:2009; EN 61000-3-2:2006 + A1:2009 + A2:2009; EN 61000-3-3:2008; EN 61000-4-2,3,4,5,6,8,11; UL 8750; IEC 60598-1:2008; IEC 60598-2-3:2002; IEC 62031:2008; IEC 62471:2008; IES LM-80; IEC 61347-1:2008; IEC 61347-2-13:2006; IEC 55015:2006; + A1:2007 + A2:2009; IEC 61547:2009; IEC 61000-3:2006; A1:2009 + A2:2009; IEC 61000-3-3:2008; IEC 6100-4-2,3,4,5,6,8,11; UL 8750;

The TKS model offers solutions of up to 100W of power, guaranteeing maximum efficiency on low or moderate speed tracks. Its die-cast aluminum structure with flat cover, and the arrangement of independent spaces for optical block and driver, provide excellent heat dissipation and a contained weight of the assembly, guaranteeing a useful life of the components exceeding 100,000 hours of operation.

It is suitable for post-top or side-entry mounting, allowing tilt adjustment to adapt perfectly to the lighting needs of each track. Its tool-free opening facilitates mounting at height for the installer, optionally allowing an electrical disconnections system on opening that offers maximum safety when being handled.

It offers multiple lighting packages, with a wide range of photometric distributions and operating currents. Allows plug & play installation of NEMA / ZHAGA socket compatible devices, ensuring easy integration with point-to-point remote management systems.



TECHNICAL DATA SHEET

TURKANA S

TURKANA S*

SPECIFICATIONS

| | |
|-----------------------|---|
| Structure | Aluminum injection |
| Diffuser | Tempered glass/polycarbonate |
| Dimensions and weight | 522x295x105 mm / 6 Kg |
| Anchoring systems | Post-top and lateral Ø up to 65 mm with rotation from 0 to 90° |
| Degree of protection | IP66, IK08 (Optional IK10) |
| Warranty | 5/7/10 years |
| Certification | CE; RoHS |
| Safety class | I/II |
| Opening | Tool-free, with optional electrical disconnection. |

OPTIONAL CONTROL SYSTEMS

Programmable regulation of up to 8 levels
 Time programming module
 (35 programs | reprogrammable from CM | winter-summer distinction)
 Point to point remote management RFLight₂
 DALI2/D4i, 1 -10V
 CLO (constant light level)
 Dimming at the head-end
 Control line dimming
 Photocell
 Socket NEMA 7 / Zhaga book 18
 Others: PLC, GPRS, 3G, NFC, NFC, Bluetooth, Narrow Band 5G

FEATURES*

| | |
|-------------------|--|
| Power | 10W-100W |
| Efficiency lm/W | Up to 170 lm/W |
| Input voltage | 90-305 V / ~ 50-60Hz (depending on model) |
| Power supply | PF > 0.95, Efficiency > 88% (depending on model) |
| Lifetime | >100.000 hours (L90B10) |
| LED Type | Cree®, Nichia®, Osram® |
| Color temperature | 1,800 K - 6,000 K / PC-Amber |
| Minimum CRI | 70/80 |
| FHS | 0% |

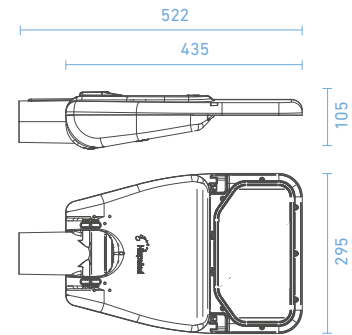

VERSIONS*

ECO

STANDARD

PREMIUM

- Including
- Optional
- ✗ Not available

OVERVOLTAGE PROTECTION

| | | | |
|---------------------|---|---|---|
| 10 kV (en f. alim.) | ● | ✗ | ✗ |
| 10 kV (SPD ext.) | ✗ | ● | ● |
| 20 kV (SPD ext.) | ✗ | ○ | ○ |

REGULATION

| | | | |
|----------------------|---|---|---|
| 8 Levels | ● | ● | ✗ |
| MPH (reprogrammable) | ✗ | ○ | ● |

OPERATING CURRENT

| | | | |
|---------|---|---|---|
| 500 mA | ○ | ○ | ● |
| 700 mA | ○ | ● | ○ |
| 1000 mA | ● | ○ | ○ |

OPTICAL BLOCK

(Consult for more optical options)



ROAD I

Recommended distribution on tracks with extreme spacings up to 6 times the pole height

ROAD II

Recommended layout for roadways with a track width similar to the height of the post

ROAD III

Recommended layout for roadways with up to two lanes with spacings up to 4 times the post height.

ROAD IV

Recommended layout on tracks with high clearances of up to 5 times the height of the pole

URBAN 360

Recommended layout for medium-height omnidirectional lighting, such as parks and squares

* Specifications are subject to change



ANDALUSIA
MUNICIPALITY OF VILLALCARRILLO (JAÉN)
Installation of TURKANA luminaires by Hispaled

VIALS



TURKANA M



Highways
and highways



Roads/
Urban roads



Parking



Logistics
platforms



Stations

TURKANAMHISPALED





Avant-garde vials with high performance and state-of-the-art LED technology

DESIGN AND PERFORMANCE

The Turkana M series is a functional road type luminaire that guarantees maximum performance on highways, freeways, roads, avenues and other main roads in the city.

Elements such as its excellent design, its high quality finish or the integration of remote management systems with easy connectivity, make it a benchmark in the street lighting market.

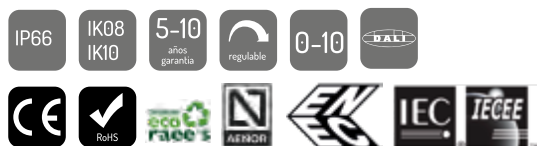

TECHNICAL DATA SHEET

ENEC 01; CE, RoHS; EN 60598-1:2009 + A1:2009; EN 60598-2-3:2003 + Corr:2005 + A1:2011; EN 62031:2009 + A1:2011; EN 62471:2008; IES LM-80; EN 61347-1:2008; EN 61347-2-13:2006; EN 55015:2006 + A1:2007 + A2:2009; EN 61547:2009; EN 61000-3-2:2006 + A1:2009 + A2:2009; EN 61000-3-3:2008; EN 61000-4-2,3,4,5,6,8,11; UL 8750; IEC 60598-1:2008; IEC 60598-2-3:2002; IEC 62031:2008; IEC 62471:2008; IES LM-80; IEC 61347-1:2008; IEC 61347-2-13:2006; IEC 55015:2006; + A1:2007 + A2:2009; IEC 61547:2009; IEC 61000-3:2006; A1:2009 + A2:2009; IEC 61000-3-3:2008; IEC 6100-4-2,3,4,5,6,8,11; UL 8750;

The TKM model offers solutions of up to 180W of power, guaranteeing maximum lighting performance on roads of any type (highways, avenues, etc.). Its die-cast aluminum structure with flat cover, and the arrangement of independent spaces for the optical compartment and driver, provide excellent heat dissipation and reduced weight of the assembly, guaranteeing a useful life of more than 100,000 hours of operation.

It is suitable for post-top or side-entry mounting, allowing tilt adjustment to adapt perfectly to the lighting needs of each track. The tool-free opening of the luminaire facilitates mounting at height for the installer, optionally allowing an electrical disconnection system on opening that offers maximum safety when being handled.

It offers multiple lighting packages, with a wide range of photometric distributions and operating currents. Allows plug & play installation of NEMA / ZHAGA socket compatible devices, ensuring easy integration with point-to-point remote management systems.



TECHNICAL DATA SHEET

TURKANA M

TURKANA M*

SPECIFICATIONS

| | |
|-----------------------|---|
| Structure | Aluminum injection |
| Diffuser | Tempered glass/polycarbonate |
| Dimensions and weight | 644x398x106 mm / 9 Kg |
| Anchoring systems | Post-top and side Ø up to 65 mm with 0 to 90° rotation |
| Degree of protection | IP66, IK08 (Optional IK10) |
| Warranty | 5/7/10 years |
| Certification | CE; RoHS |
| Safety class | I/II |
| Opening | Tool-free, with optional electrical disconnection. |

OPTIONAL CONTROL SYSTEMS

Programmable regulation of up to 8 levels
 Time programming module
 (35 progrs. | reprogrammable from CM | Winter-Summer distinction)
 Point-to-point remote management RFLight₂
 DALI2/D4i, 1 -10V
 CLO (constant light level)
 Head-end regulation
 Control line regulation
 Photocell
 Socket NEMA 7 / Zhaga book 18
 Otros: PLC, GPRS, 3G, NFC, Bluetooth, Narrow Band 5G

FEATURES*

| | |
|-------------------|--|
| Power | 40W-200W |
| Efficiency lm/W | Up to 170 lm/W |
| Input voltage | 90-305 V / ~ 50-60Hz (depending on model) |
| Power supply | PF > 0.95, Efficiency > 88% (depending on model) |
| Lifetime | >100,000 hours (L90B10) |
| LED Type | Cree®, Nichia®, Osram®, Osram® |
| Color temperature | 1,800 K - 6,000 K / PC-Amber |
| Minimum CRI | 70/80 |
| FHS | 0% |

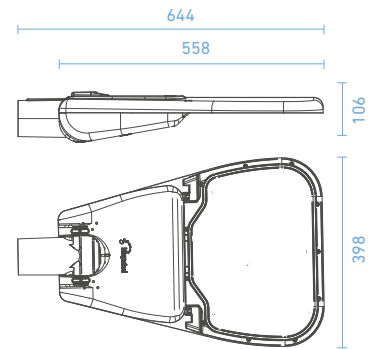

VERSIONS*

ECO

STANDARD

PREMIUM

- Included
- Optional
- ✗ Not available

OVERVOLTAGE PROTECTION

| | | | |
|---------------------|---|---|---|
| 10 kV (en f. alim.) | ● | ✗ | ✗ |
| 10 kV (SPD ext.) | ✗ | ● | ● |
| 20 kV (SPD ext.) | ✗ | ○ | ○ |

REGULATION

| | | | |
|----------------------|---|---|---|
| 8 Levels | ● | ● | ✗ |
| MPH (reprogrammable) | ✗ | ○ | ● |

OPERATING CURRENT

| | | | |
|---------|---|---|---|
| 500 mA | ○ | ○ | ● |
| 700 mA | ○ | ● | ○ |
| 1000 mA | ● | ○ | ○ |

OPTICAL BLOCK

(Consult for more optical options)



ROAD I

Recommended distribution on tracks with extreme spacings up to 6 times the pole height

ROAD II

Recommended layout for roadways with a track width similar to the height of the height of the pole

ROAD III

Recommended layout for roadways with up to two lanes with spacings up to 4 times the pole height.

ROAD IV

Recommended distribution on tracks with high clearances of up to 5 times the height of the pole

URBAN 360

Recommended distribution for medium-height omnidirectional lighting, such as parks and squares

* Specifications are subject to change



ANDALUSIA
CITY COUNCIL OF LA LÍNEA DE LA CONCEPCIÓN (CÁDIZ)
Installation of TURKANA luminaires of Hispaled

ORNAMENTALS



SENDA S



Residential streets



Pedestrian spaces



Parks and gardens



Bicycle lanes

SENDASHISPALED





Urban luminaire with modern design, ideal for ambient lighting

EFFICIENCY AND MODERNITY

The Senda S series is a decorative luminaire with a modern design and simple lines, which makes it an optimal solution for ambient lighting.

Innovative design and efficiency are combined in an urban luminaire that offers the best ratio between savings and investment in ambient lighting, thanks to its affordable price and high performance.

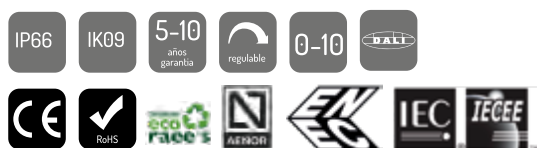

TECHNICAL DATA SHEET

ENEC 01; CE, RoHS; EN 60598-1:2009 + A1:2009; EN 60598-2-3:2003 + Corr:2005 + A1:2011; EN 62031:2009 + A1:2011; EN 62471:2008; IES LM-80; EN 61347-1:2008; EN 61347-2-13:2006; EN 55015:2006 + A1:2007 + A2:2009; EN 61547:2009; EN 61000-3-2:2006 + A1:2009 + A2:2009; EN 61000-3-3:2008; EN 61000-4-2,3,4,5,6,8,11; UL 8750; IEC 60598-1:2008; IEC 60598-2-3:2002; IEC 62031:2008; IEC 62471:2008; IES LM-80; IEC 61347-1:2008; IEC 61347-2-13:2006; IEC 55015:2006 + A1:2007 + A2:2009; IEC 61547:2009; IEC 61000-3-2:2006 + A1:2009 + A2:2009; IEC 61000-3-3:2008; IEC 61000-4-2,3,4,5,6,8,11; UL 8750;

The SNS model offers solutions of up to 60W of power, guaranteeing optimum results in environmental applications, such as lighting of parks, squares, avenues, and other urban spaces. Its hemispherical structure of injected aluminum and its high degree of watertightness and protection against impacts, make it an anti-vandalism and durable product, guaranteeing a useful life of the components of more than 100,000 hours of operation.

It is suitable for post-top or side-entry mounting, allowing tilt adjustment to adapt perfectly to the lighting needs of each track. Its tool-free opening facilitates mounting at height for the installer, optionally allowing an electrical disconnections system on opening that offers maximum safety when being handled.

It offers multiple lighting packages, with a wide range of photometric distributions and operating currents. It also allows "plug & play" installation of NEMA / ZHAGA socket compatible devices, which guarantees easy integration with point-to-point remote management systems.

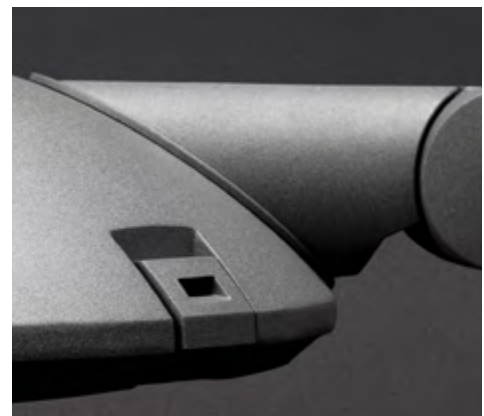
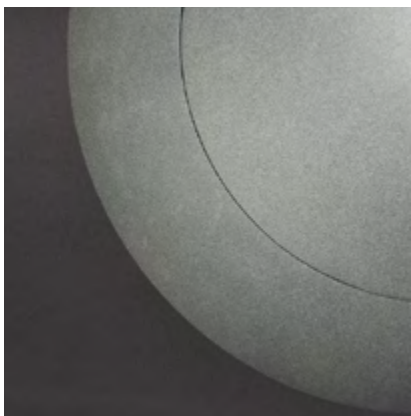

TECHNICAL DATA SHEET

SENDA S

SENDA S*

SPECIFICATIONS

| | |
|-----------------------|---|
| Structure | Aluminum injection |
| Diffuser | Tempered glass |
| Dimensions and weight | H 112 mm 380 mm / 4Kg |
| Anchoring systems | Post-top, lateral, suspended and catenary Ø up to 60 mm with 0 to 90° rotation |
| Degree of protection | IP66, IK09 |
| Warranty | 5/7/10 years |
| Certification | CE; RoHS |
| Safety class | I/II |
| Opening | Tool-free, with optional electrical disconnection. |

OPTIONAL CONTROL SYSTEMS

Programmable regulation of up to 8 levels
 Time programming module
 (35 programs | reprogrammable from CM | winter-summer distinction)
 Point to point remote management RFLight2
 DALI2/D4i, 1 -10V
 CLO (constant light level)
 Dimming at the head-end
 Control line dimming
 Photocell
 Socket NEMA 7 / Zhaga book 18
 Others: PLC, GPRS, 3G, NFC, NFC, Bluetooth, Narrow Band 5G

FEATURES*

| | |
|-------------------|--|
| Power | 10W-60W |
| Efficiency lm/W | Up to 170 lm/W |
| Input voltage | 90-305 V / ~ 50-60Hz (depending on model) |
| Power supply | PF > 0.95, Efficiency > 88% (depending on model) |
| Lifetime | >100,000 hours (L90B10) |
| LED Type | Cree®, Nichia®, Osram® |
| Color temperature | 1,800 K - 6,000 K / PC-Amber |
| Minimum CRI | 70/80 |
| FHS | 0% |

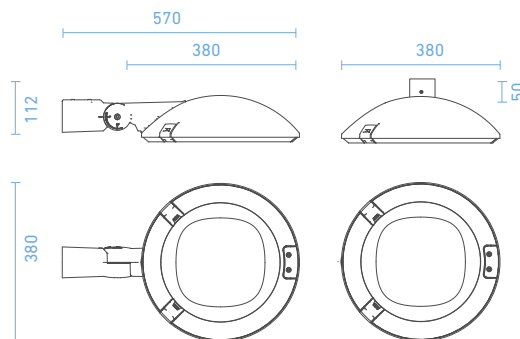

VERSIONS*

ECO

STANDARD

PREMIUM

- Included
- Optional
- ✗ Not available

OVERVOLTAGE PROTECTION

| | | | |
|---------------------|---|---|---|
| 10 kV (en f. alim.) | ● | ✗ | ✗ |
| 10 kV (SPD ext.) | ✗ | ● | ● |
| 20 kV (SPD ext.) | ✗ | ○ | ○ |

REGULATION

| | | | |
|----------------------|---|---|---|
| 8 Levels | ● | ● | ✗ |
| MPH (reprogrammable) | ✗ | ○ | ● |

OPERATING CURRENT

| | | | |
|---------|---|---|---|
| 500 mA | ○ | ○ | ● |
| 700 mA | ○ | ● | ○ |
| 1000 mA | ● | ○ | ○ |

OPTICAL BLOCK

(Consult for more optical options)

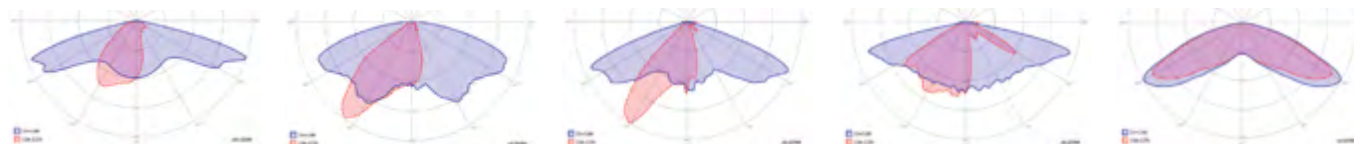

ROAD I

Recommended distribution on tracks with extreme spacings up to 6 times the pole height

ROAD II

Recommended layout for roadways with a track width similar to the height of the pole

ROAD III

Recommended layout for roadways with up to two lanes with spacings up to 4 times the pole height.

ROAD IV

Recommended distribution on tracks with high clearances of up to 5 times the height of the pole

URBAN 360

Recommended distribution for medium-height omnidirectional lighting, such as parks and squares

* Specifications are subject to change



CASTILLA Y LEÓN
NAVA DE LA ASUNCIÓN CITY COUNCIL (SEGOVIA)
Installation of Hispaled SENDA luminaires.

ORNAMENTALS



SENDAM



Roads/
Urban roads



Residential
streets



Pedestrian
spaces



Parks
and gardens



Bicycle lanes

SENDAMHISPALED





Urban luminaire with modern design, ideal for ambient lighting

EFFICIENCY AND MODERNITY

The Senda M series is a decorative luminaire with a modern design and simple lines, which makes it an optimal solution for ambient lighting.

Innovative design and efficiency are combined in an urban luminaire that offers the best ratio between savings and investment in ambient lighting, thanks to its affordable price and high performance.



TECHNICAL DATA SHEET

ENEC 01; CE, RoHS; EN 60598-1:2009 + A1:2009; EN 60598-2-3:2003 + Corr:2005 + A1:2011; EN 62031:2009 + A1:2011; EN 62471:2008; IES LM-80; EN 61347-1:2008; EN 61347-2-13:2006; EN 55015:2006 + A1:2007 + A2:2009; EN 61547:2009; EN 61000-3-2:2006 + A1:2009 + A2:2009; EN 61000-3-3:2008; EN 61000-4-2,3,4,5,6,8,11; UL 8750; IEC 60598-1:2008; IEC 60598-2-3:2002; IEC 62031:2008; IEC 62471:2008; IES LM-80; IEC 61347-1:2008; IEC 61347-2-13:2006; IEC 55015:2006 + A1:2007 + A2:2009; IEC 61547:2009; IEC 61000-3-2:2006 + A1:2009 + A2:2009; IEC 61000-3-3:2008; IEC 61000-4-2,3,4,5,6,8,11; UL 8750;

The SNM model offers solutions of up to 100W of power, guaranteeing optimum results in environmental applications, such as lighting of parks, squares, avenues, and other urban spaces. Its hemispherical structure of injected aluminum and its high degree of watertightness and protection against impacts, make it an anti-vandal and durable product, guaranteeing a useful life of the components of more than 100,000 hours of operation.

It is suitable for post-top or side-entry mounting, allowing inclination adjustment to adapt perfectly to the lighting needs of each track. It can be opened without tools, which facilitates installation at height for the installer, optionally allowing an electrical disconnection system when opening, which offers maximum safety when being handled.

It offers multiple lighting packages, with a wide range of photometric distributions and operating currents. It also allows "plug & play" installation of NEMA / ZHAGA socket compatible devices, which guarantees easy integration with point-to-point remote management systems.



SENDA M

SENDA M*

SPECIFICATIONS

| | |
|-----------------------|---|
| Structure | Aluminum injection |
| Diffuser | Tempered glass |
| Dimensions and weight | H 224 mm 520 mm / 7Kg |
| Anchoring systems | Post-top, lateral, suspended and catenary Ø up to 60 mm with 0 to 90° rotation |
| Degree of protection | IP66, IK09 |
| Warranty | 5/7/10 years |
| Certification | CE; RoHS |
| Safety class | I/II |
| Opening | Tool-free, with optional electrical disconnection. |

OPTIONAL CONTROL SYSTEMS

Programmable regulation of up to 8 levels
 Time programming module
 (35 programs | reprogrammable from CM | winter-summer distinction)
 Point to point remote management RFLight2
 DALI2/D4i, 1 -10V
 CLO (constant light level)
 Dimming at the head-end
 Control line dimming
 Photocell
 Socket NEMA 7 / Zhaga book 18
 Others: PLC, GPRS, 3G, NFC, NFC, Bluetooth, Narrow Band 5G

FEATURES*

| | |
|-------------------|--|
| Power | 10W-100W |
| Efficiency lm/W | Up to 170 lm/W |
| Input voltage | 90-305 V / ~ 50-60Hz (depending on model) |
| Power supply | PF > 0.95, Efficiency > 88% (depending on model) |
| Lifetime | >100,000 hours (L90B10) |
| LED Type | Cree®, Nichia®, Osram® |
| Color temperature | 1,800 K - 6,000 K / PC-Amber |
| Minimum CRI | 70/80 |
| FHS | 0% |

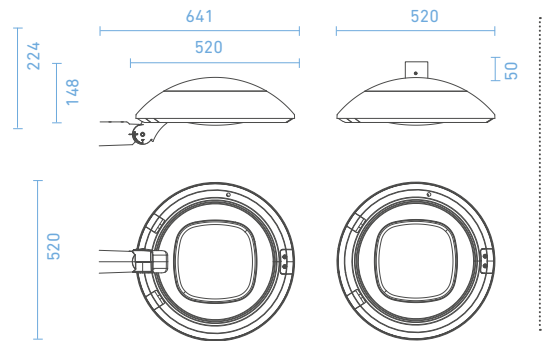

VERSIONS*

ECO

STANDARD

PREMIUM

- Included
- Optional
- ✕ Not available

OVERVOLTAGE PROTECTION

| | | | |
|---------------------|---|---|---|
| 10 kV (en f. alim.) | ● | ✕ | ✕ |
| 10 kV (SPD ext.) | ✕ | ● | ● |
| 20 kV (SPD ext.) | ✕ | ○ | ○ |

REGULATION

| | | | |
|----------------------|---|---|---|
| 8 Levels | ● | ● | ✕ |
| MPH (reprogrammable) | ✕ | ○ | ● |

OPERATING CURRENT

| | | | |
|---------|---|---|---|
| 500 mA | ○ | ○ | ● |
| 700 mA | ○ | ● | ○ |
| 1000 mA | ● | ○ | ○ |

OPTICAL BLOCK

(Consult for more optical options)



ROAD I

Recommended distribution on tracks with extreme spacings up to 6 times the pole height

ROAD II

Recommended layout for roadways with a track width similar to the height of the height of the pole

ROAD III

Recommended layout for roadways with up to two lanes with spacings up to 4 times the pole height.

ROAD IV

Recommended distribution on tracks with high clearances of up to 5 times the height of the pole

URBAN 360

Recommended distribution for medium-height omnidirectional lighting, such as parks and squares

* Specifications are subject to change



ANDALUSIA
VILCHES CITY COUNCIL (JAÉN)
Installation of Hispaled SENDA luminaires.

ORNAMENTALS



STYLO S



Residential streets



Pedestrian areas



Parks and gardens



Bicycle lanes

STYLOSHISPALED





Environmental luminaire with avant-garde and vandal-proof design

VERSATILITY AND VANGUARDISM

Hispaled's Stylo S series is a modern design solution with an avant-garde touch, perfect for public lighting of streets, promenades, parks, squares or gardens.

Its double arm aesthetics allows the light point to be raised in height, improving on the one hand the levels of uniformity on the track, and making its design a perfect anti-vandalism solution.

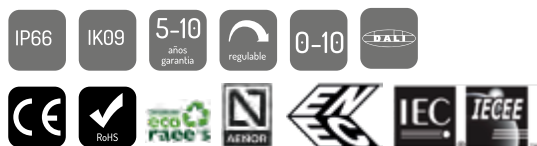

TECHNICAL DATA SHEET

ENEC 01; CE, RoHS; EN 60598-1:2009 + A1:2009; EN 60598-2-3:2003 + Corr:2005 + A1:2011; EN 62031:2009 + A1:2011; EN 62471:2008; IES LM-80; EN 61347-1:2008; EN 61347-2-13:2006; EN 55015:2006 + A1:2007 + A2:2009; EN 61547:2009; EN 61000-3-2:2006 + A1:2009 + A2:2009; EN 61000-3-3:2008; EN 61000-4-2,3,4,5,6,8,11; UL 8750; IEC 60598-1:2008; IEC 60598-2-3:2002; IEC 62031:2008; IEC 62471:2008; IES LM-80; IEC 61347-1:2008; IEC 61347-2-13:2006; IEC 55015:2006 + A1:2007 + A2:2009; IEC 61547:2009; IEC 61000-3-2:2006 + A1:2009 + A2:2009; IEC 61000-3-3:2008; IEC 61000-4-2,3,4,5,6,8,11; UL 8750;

The STS model offers solutions of up to 60W of power, guaranteeing optimal results in environmental applications, such as lighting of parks, squares, avenues, and other urban spaces. Its hemispherical structure of injected aluminum and its high degree of watertightness and protection against impacts, make it an anti-vandal and durable product, guaranteeing a useful life of the components of more than 100,000 hours of operation.

It is suitable for post-top or side-entry mounting, allowing inclination adjustment to adapt perfectly to the lighting needs of each track. It can be opened without tools, which facilitates installation at height for the installer, optionally allowing an electrical disconnection system when opening, which offers maximum safety when being handled.

It offers multiple lighting packages, with a wide range of photometric distributions and operating currents. It also allows "plug & play" installation of NEMA / ZHAGA socket compatible devices, which guarantees easy integration with point-to-point remote management systems.



TECHNICAL DATA SHEET

STYLO S

STYLO S*

SPECIFICATIONS

| | |
|-----------------------|---|
| Structure | Aluminum injection |
| Diffuser | Tempered glass |
| Dimensions and weight | H 511 mm Ø 380 mm / 5Kg |
| Anchoring systems | Post-top Ø up to 80 mm |
| Degree of protection | IP66, IK09 |
| Warranty | 5/7/10 years |
| Certification | CE; RoHS |
| Safety class | I/II |
| Opening | Tool-free, with optional electrical disconnection. |

OPTIONAL CONTROL SYSTEMS

Programmable regulation of up to 8 levels
 Time programming module
 (35 programs | reprogrammable from CM | winter-summer distinction)
 Point to point remote management RFLight₂
 DALI2/D4i, 1 -10V
 CLO (constant light level)
 Dimming at the head-end
 Control line dimming
 Photocell
 Socket NEMA 7 / Zhaga book 18
 Others: PLC, GPRS, 3G, NFC, NFC, Bluetooth, Narrow Band 5G

FEATURES*

| | |
|-------------------|--|
| Power | 10W-60W |
| Efficiency lm/W | Up to 170 lm/W |
| Input voltage | 90-305 V / ~ 50-60Hz (depending on model) |
| Power supply | PF > 0.95, Efficiency > 88% (depending on model) |
| Lifetime | >100,000 hours (L90B10) |
| LED Type | Cree®, Nichia®, Osram® |
| Color temperature | 1,800 K - 6,000 K / PC-Amber |
| Minimum CRI | 70/80 |
| FHS | 0% |

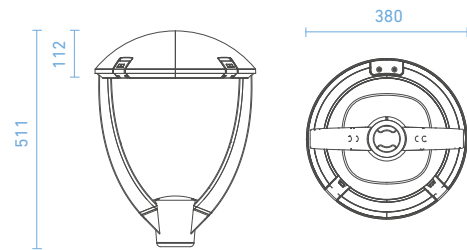

VERSIONS*

ECO

STANDARD

PREMIUM

- Included
- Optional
- ✗ Not available

OVERVOLTAGE PROTECTION

| | | | |
|---------------------|---|---|---|
| 10 kV (en f. alim.) | ● | ✗ | ✗ |
| 10 kV (SPD ext.) | ✗ | ● | ● |
| 20 kV (SPD ext.) | ✗ | ○ | ○ |

REGULATION

| | | | |
|----------------------|---|---|---|
| 8 Levels | ● | ● | ✗ |
| MPH (reprogrammable) | ✗ | ○ | ● |

OPERATING CURRENT

| | | | |
|---------|---|---|---|
| 500 mA | ○ | ○ | ● |
| 700 mA | ○ | ● | ○ |
| 1000 mA | ● | ○ | ○ |

OPTICAL BLOCK

(Consult for more optical options)



ROAD I

Recommended distribution on tracks with extreme spacings up to 6 times the pole height

ROAD II

Recommended layout for roadways with a track width similar to the height of the height of the pole

ROAD III

Recommended layout for roadways with up to two lanes with spacings up to 4 times the pole height.

ROAD IV

Recommended distribution on tracks with high clearances of up to 5 times the height of the pole

URBAN 360

Recommended distribution for medium-height omnidirectional lighting, such as parks and squares

* Specifications are subject to change



ANDALUSIA
PALMA DEL CONDADO CITY COUNCIL (HUELVA)
Installation of Hispaled STYLO luminaires.

ORNAMENTALS



STYLO M



Roads/
Urban roads



Residential
streets



Pedestrian
areas



Parks
and gardens



Bicycle lanes

STYLOM HISPALÉ





Environmental luminaire with avant-garde and vandal-proof design

VERSATILITY AND VANGUARDISM

Hispaled's Stylo M series is a modern design solution with an avant-garde touch, perfect for public lighting of streets, promenades, parks, squares or gardens.

Its double arm aesthetics allows the light point to be raised in height, improving on the one hand the levels of uniformity on the track, and making its design a perfect anti-vandalism solution.



TECHNICAL DATA SHEET

ENEC 01; CE, RoHS; EN 60598-1:2009 + A1:2009; EN 60598-2-3:2003 + Corr:2005 + A1:2011; EN 62031:2009 + A1:2011; EN 62471:2008; IES LM-80; EN 61347-1:2008; EN 61347-2-13:2006; EN 55015:2006 + A1:2007 + A2:2009; EN 61547:2009; EN 61000-3-2:2006 + A1:2009 + A2:2009; EN 61000-3-3:2008; EN 61000-4-2,3,4,5,6,8,11; UL 8750; IEC 60598-1:2008; IEC 60598-2-3:2002; IEC 62031:2008; IEC 62471:2008; IES LM-80; IEC 61347-1:2008; IEC 61347-2-13:2006; IEC 55015:2006; + A1:2007 + A2:2009; IEC 61547:2009; IEC 61000-3:2006; A1:2009 + A2:2009; IEC 61000-3-3:2008; IEC 61000-4-2,3,4,5,6,8,11; UL 8750;

The STM model offers solutions of up to 100W of power, guaranteeing optimal results in environmental applications, such as lighting of parks, squares, avenues, and other urban spaces. Its hemispherical structure of injected aluminum and its high degree of watertightness and protection against impacts, make it an anti-vandalism and durable product, guaranteeing a useful life of the components of more than 100,000 hours of operation.

It is suitable for post-top or side-entry mounting, allowing tilt adjustment to adapt perfectly to the lighting needs of each track. It can be opened without tools, which facilitates installation at height for the installer, optionally allowing an electrical disconnection system when opening, which offers maximum safety when being handled.

It offers multiple lighting packages, with a wide range of photometric distributions and operating currents. It also allows "plug & play" installation of NEMA / ZHAGA socket compatible devices, which guarantees easy integration with point-to-point remote management systems.

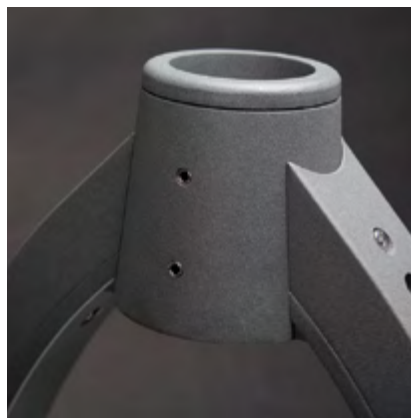
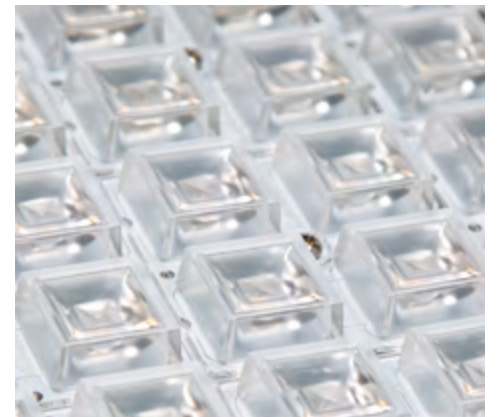
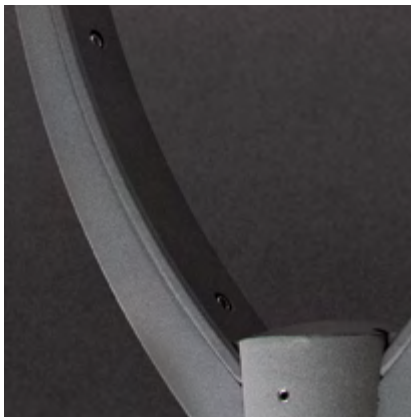

TECHNICAL DATA SHEET

STYLO M

STYLO M*

SPECIFICATIONS

| | |
|-----------------------|---|
| Structure | Aluminum injection |
| Diffuser | Tempered glass |
| Dimensions and weight | H 627 mm Ø 520 mm / 8Kg |
| Anchoring systems | Post-top Ø up to 80 mm |
| Degree of protection | IP66, IK09 |
| Warranty | 5/7/10 years |
| Certification | CE; RoHS |
| Safety class | I/II |
| Opening | Tool-free, with optional electrical disconnection. |

OPTIONAL CONTROL SYSTEMS

Programmable regulation of up to 8 levels
 Time programming module
 (35 programs | reprogrammable from CM | winter-summer distinction)
 Point to point remote management RFLight2
 DALI2/D4i, 1 -10V
 CLO (constant light level)
 Dimming at the head-end
 Control line dimming
 Photocell
 Socket NEMA 7 / Zhaga book 18
 Others: PLC, GPRS, 3G, NFC, NFC, Bluetooth, Narrow Band 5G

FEATURES*

| | |
|-------------------|--|
| Power | 10W-100W |
| Efficiency lm/W | Up to 170 lm/W |
| Input voltage | 90-305 V / ~ 50-60Hz (depending on model) |
| Power supply | PF > 0.95, Efficiency > 88% (depending on model) |
| Lifetime | >100,000 hours (L90B10) |
| LED Type | Cree®, Nichia®, Osram® |
| Color temperature | 1,800 K - 6,000 K / PC-Amber |
| Minimum CRI | 70/80 |
| FHS | 0% |

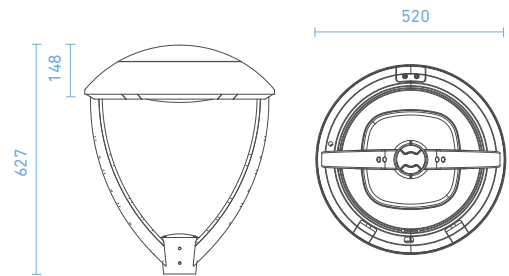

VERSIONS*

ECO

STANDARD

PREMIUM

- Included
- Optional
- ✕ Not available

OVERVOLTAGE PROTECTION

| | | | |
|---------------------|---|---|---|
| 10 kV (en f. alim.) | ● | ✕ | ✕ |
| 10 kV (SPD ext.) | ✕ | ● | ● |
| 20 kV (SPD ext.) | ✕ | ○ | ○ |

REGULATION

| | | | |
|----------------------|---|---|---|
| 8 Levels | ● | ● | ✕ |
| MPH (reprogrammable) | ✕ | ○ | ● |

OPERATING CURRENT

| | | | |
|---------|---|---|---|
| 500 mA | ○ | ○ | ● |
| 700 mA | ○ | ● | ○ |
| 1000 mA | ● | ○ | ○ |

OPTICAL BLOCK

(Consult for more optical options)

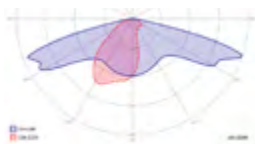

ROAD I

Recommended distribution on tracks with extreme spacings up to 6 times the pole height

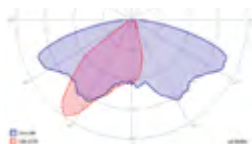

ROAD II

Recommended layout for roadways with a track width similar to the height of the pole



ROAD III

Recommended layout for roadways with up to two lanes with spacings up to 4 times the pole height.

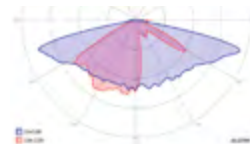

ROAD IV

Recommended distribution on tracks with high clearances of up to 5 times the height of the pole



URBAN 360

Recommended distribution for medium-height omnidirectional lighting, such as parks and squares

* Specifications are subject to change



EXTREMADURA
CITY COUNCIL OF CASTUERA (BADAJOZ)
Installation of Hispaléd's STYLO luminaire.

ORNAMENTALS



VILLA S/M/X



Historical and monumental



Residential streets



Pedestrian areas



Parks and gardens



Bicycle lanes

VILLAS/M/XHISPALED





Classic lantern par excellence, ideal for lighting at low heights

PERSONALITY AND EFFICIENCY

The Villa series by Hispaled is a luminaire with a classic and timeless design, ideal for low-level lighting of pedestrian areas and residential streets, as well as parks, squares or gardens.

Personality, quality and state-of-the-art LED technology are elements that come together in this lantern, providing a market-leading solution for this type of luminaire.



TECHNICAL DATA SHEET

ENEC 01; CE, RoHS; EN 60598-1:2009 + A1:2009; EN 60598-2-3:2003 + Corr:2005 + A1:2011; EN 62031:2009 + A1:2011; EN 62471:2008; IES LM-80; EN 61347-1:2008; EN 61347-2-13:2006; EN 55015:2006 + A1:2007 + A2:2009; EN 61547:2009; EN 61000-3-2:2006 + A1:2009 + A2:2009; EN 61000-3-3:2008; EN 61000-4-2,3,4,5,6,8,11; UL 8750; IEC 60598-1:2008; IEC 60598-2-3:2002; IEC 62031:2008; IEC 62471:2008; IES LM-80; IEC 61347-1:2008; IEC 61347-2-13:2006; IEC 55015:2006 + A1:2007 + A2:2009; IEC 61547:2009; IEC 61000-3-2:2006 + A1:2009 + A2:2009; IEC 61000-3-3:2008; IEC 61000-4-2,3,4,5,6,8,11; UL 8750;

Within the Villa Series family, the VLM model offers solutions of up to 80W of power, guaranteeing maximum efficiency in residential streets, pedestrian areas, squares, parks or gardens. Its single-piece die-cast aluminum structure and its high degree of watertightness and impact protection make it a vandal-proof and durable product, guaranteeing a component life of more than 100,000 hours of operation.

It is suitable for mounting on columns, wall brackets or suspended. This classic style lantern offers multiple light packages, with a wide range of photometric distributions and operating currents. Likewise, the closure of the optical compartment offers two different types of finishes, transparent or satin. The former guarantees maximum efficiency in lm/W and the latter significantly improves visual comfort for pedestrians and drivers, giving this lantern an element of extraordinary personality, unique in the market. There is the possibility of incorporating transparent or translucent side diffusers, honeycomb diffusers, etc.



TECHNICAL DATA SHEET

VILLA S/M/X

VILLA S/M/X*

SPECIFICATIONS

| | |
|-----------------------|--|
| Structure | Aluminum injection |
| Optical Diffuser | High-strength PC, anti-U.V. treatment. |
| Lateral diffusers | Optional (Honeycomb/transparent/translucent) |
| Dimensions and weight | W 355/400/440 mm H 610/703/750 mm / 7/8/8Kg |
| Anchoring systems | Column end, lever or suspended |
| Gradual inclination | Optional |
| Degree of protection | IP66, IK09/IK10 |
| Warranty | 5/7/10 years |
| Certification | CE; RoHS |
| Safety class | I/II |

OPTIONAL CONTROL SYSTEMS

Programmable regulation of up to 8 levels
 Time programming module
 (35 programs | reprogrammable from CM | winter-summer distinction)
 Point to point remote management RFLight₂
 DALI2/D4i, 1 -10V
 CLO (constant light level)
 Dimming at the head-end
 Control line dimming
 Photocell
 Socket NEMA 7 / Zhaga book 18
 Others: PLC, GPRS, 3G, NFC, NFC, Bluetooth, Narrow Band 5G

FEATURES*

| | |
|-------------------|--|
| Power | 10W-80W |
| Efficiency lm/W | Up to 170 lm/W |
| Input voltage | 90-305 V / ~ 50-60Hz (depending on model) |
| Power supply | PF > 0.95, Efficiency > 88% (depending on model) |
| Lifetime | >100,000 hours (L90B10) |
| LED Type | Cree®, Nichia®, Osram® |
| Color temperature | 1,800 K - 6,000 K / PC-Amber |
| Minimum CRI | 70/80 |
| FHS | 0% |

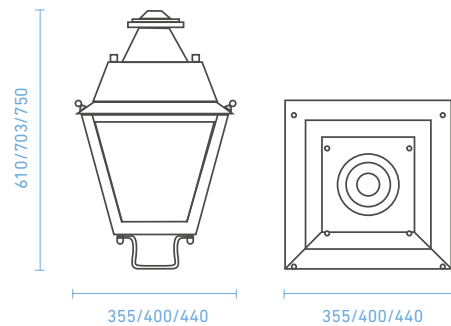

VERSIONS*

ECO

STANDARD

PREMIUM

- Included
- Optional
- ✗ Not available

OVERVOLTAGE PROTECTION

| | | | |
|---------------------|---|---|---|
| 10 kV (en f. alim.) | ● | ✗ | ✗ |
| 10 kV (SPD ext.) | ✗ | ● | ● |
| 20 kV (SPD ext.) | ✗ | ○ | ○ |

REGULATION

| | | | |
|----------------------|---|---|---|
| 8 Levels | ● | ● | ✗ |
| MPH (reprogrammable) | ✗ | ○ | ● |

OPERATING CURRENT

| | | | |
|---------|---|---|---|
| 500 mA | ○ | ○ | ● |
| 700 mA | ○ | ● | ○ |
| 1000 mA | ● | ○ | ○ |

OPTICAL BLOCK

(Consult for more optical options)



ROAD I

Recommended distribution on tracks with extreme spacings up to 6 times the pole height

ROAD II

Recommended layout for roadways with a track width similar to the height of the pole

ROAD III

Recommended layout for roadways with up to two lanes with spacings up to 4 times the pole height.

ROAD IV

Recommended distribution on tracks with high clearances of up to 5 times the height of the pole

URBAN 360

Recommended distribution for medium-height omnidirectional lighting, such as parks and squares

* Specifications are subject to change



MADRID
MOSTOLES CITY COUNCIL (MADRID)
Installation of lighting fixtures VILLA of Hispaled

ORNAMENTALS



FERNANDINO



Historical and
monumental



Residential
streets



Pedestrian areas



Parks
and gardens

FERNANDINOHISPALED





Classic lantern for illumination of singular areas and historical centers

ELEGANCE AND STRENGTH

Hispaled's Fernandino series is a classic style luminaire, ideal for lighting unique historical areas thanks to its majestic and traditional design.

Vandal-resistant design and state-of-the-art LED technology are combined in a lantern that remains unalterable over time, making it a benchmark in the lighting of monumental and historical spaces.



TECHNICAL DATA SHEET

CE; RoHS; EN 60598-1:2009 + A11:2009; EN 60598-2-3:2003 + Corr:2005 + A1:2011; EN 62031:2009 + A1:2011; EN 62471:2008; IES LM-80; EN 61347-1:2008; EN 61347-2-13:2006; EN 62384:2006/A1:2010; EN 55015:2006 + A1:2007 + A2:2009; EN 61547:2009; EN 61000-3-2:2006 + A1:2009 + A2:2009; EN 61000-3-3:2008; EN 61000-4-2,3,4,5,6,8,11; UL 8750; IEC 60598-1:2008; IEC 60598-2-3:2002; IEC 62031:2008; IEC 62471:2008; IES LM-80; IEC 61347-1:2008; IEC 61347-2-13:2006; IEC 55015:2006 + A1:2007 + A2:2009; IEC 61547:2009; IEC 61000-3-2:2006 + A1:2009 + A2:2009; IEC 61000-3-3:2008; IEC 61000-4-2,3,4,5,6,8,11; UL 8750;

It offers solutions of up to 80W of power, allowing a combination of elegance and efficiency in monumental areas and historical centers, where its classic and timeless design never goes out of fashion.

Its die-cast aluminum structure and its high degree of watertightness and impact protection make it an anti-vandal and durable product, guaranteeing a component life of more than 100,000 hours of operation. It is suitable for mounting on columns, wall brackets or suspended.

This classic style lantern offers multiple light packages, with a wide range of photometric distributions and operating currents. Likewise, the closure of the optical compartment offers two different types of finishes, transparent or satin. The former guarantees maximum efficiency in lm/W and the latter significantly improves visual comfort for pedestrians and drivers, giving this lantern an element of extraordinary personality, unique in the market. There is the possibility of incorporating transparent or translucent side diffusers, honeycomb diffusers, etc.

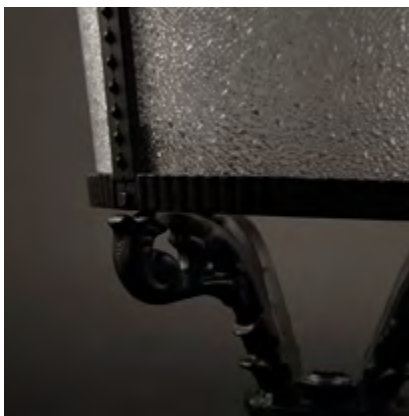

TECHNICAL DATA SHEET

FERNANDINO

FERNANDINO*

SPECIFICATIONS

| | |
|-----------------------|--|
| Structure | Aluminum injection |
| Optical Diffuser | High-strength PC, anti-U.V. treatment. |
| Lateral diffusers | Optional (Honeycomb/transparent/translucent) |
| Dimensions and weight | H 850 mm Ø 500 mm / 8Kg |
| Anchoring systems | Column end, lever or suspended |
| Degree of protection | IP66/IK09/IK10 |
| Warranty | 5/7/10 years |
| Certification | CE; RoHS |
| Safety class | I/II |

OPTIONAL CONTROL SYSTEMS

Programmable regulation of up to 8 levels
 Time programming module
 (35 programs | reprogrammable from CM | winter-summer distinction)
 Point to point remote management RFLight₂
 DALI2/D4i, 1 -10V
 CLO (constant light level)
 Dimming at the head-end
 Control line dimming
 Photocell
 Socket NEMA 7 / Zhaga book 18
 Others: PLC, GPRS, 3G, NFC, NFC, Bluetooth, Narrow Band 5G

FEATURES*

| | |
|-------------------|--|
| Power | 10W-80W |
| Efficiency lm/W | Up to 170 lm/W |
| Input voltage | 90-305 V / ~ 50-60Hz (depending on model) |
| Power supply | PF > 0.95, Efficiency > 88% (depending on model) |
| Lifetime | >100,000 hours (L90B10) |
| LED Type | Cree®, Nichia®, Osram® |
| Color temperature | 1,800 K - 6,000 K / PC-Amber |
| Minimum CRI | 70/80 |
| FHS | 0% |

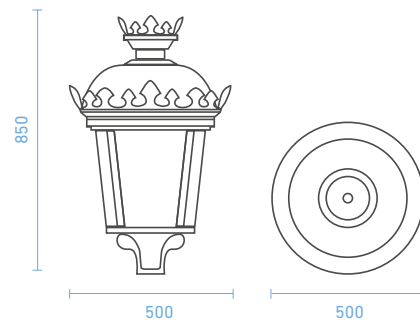

VERSIONS*

ECO

STANDARD

PREMIUM

- Included
- Optional
- ✗ Not available

OVERVOLTAGE PROTECTION

| | | | |
|---------------------|---|---|---|
| 10 kV (en f. alim.) | ● | ✗ | ✗ |
| 10 kV (SPD ext.) | ✗ | ● | ● |
| 20 kV (SPD ext.) | ✗ | ○ | ○ |

REGULATION

| | | | |
|----------------------|---|---|---|
| 8 Levels | ● | ● | ✗ |
| MPH (reprogrammable) | ✗ | ○ | ● |

OPERATING CURRENT

| | | | |
|---------|---|---|---|
| 500 mA | ○ | ○ | ● |
| 700 mA | ○ | ● | ○ |
| 1000 mA | ● | ○ | ○ |

OPTICAL BLOCK

(Consult for more optical options)



ROAD I

Recommended distribution on tracks with extreme spacings up to 6 times the pole height

ROAD II

Recommended layout for roadways with a track width similar to the height of the pole

ROAD III

Recommended layout for roadways with up to two lanes with spacings up to 4 times the pole height.

ROAD IV

Recommended distribution on tracks with high clearances of up to 5 times the height of the pole

URBAN 360

Recommended distribution for medium-height omnidirectional lighting, such as parks and squares

* Specifications are subject to change



CASTILLA Y LEÓN
CUELLAR CITY COUNCIL (SEGOVIA)
Installation of Hispaled's FERNANDINO luminaires.

RETROFIT



RETROFIT



Historical and monumental



Calles residenciales



Residential streets



Pedestrian areas



Parks and gardens



Bicycle lane

RETROFITHISPALED





Tailor-made solution for retrofitting existing streetlight to LED technology

VERSATILITY AND COST-EFFECTIVENESS

HispaLED's Retrofit series is an optical compartment that allows direct and customized adaptation to existing ornamental lanterns, both classic and modern.

Practical and economical solution for the renovation of traditional discharge luminaires, which allows to reduce energy costs and enjoy all the advantages of LED lighting, with a very low investment.



TECHNICAL DATA SHEET

CE; RoHS; EN 60598-1:2009 + A1:2009; EN 60598-2-3:2003 + Corr:2005 + A1:2011; EN 62031:2009 + A1:2011; EN 62471:2008; IES LM-80; EN 61347-1:2008; EN 61347-2-13:2006; EN 55015:2006 + A1:2007 + A2:2009; EN 61547:2009; EN 61000-3-2:2006 + A1:2009 + A2:2009; EN 61000-3-3:2008; EN 61000-4-2,3,4,5,6,8,11; UL 8750; IEC 60598-1:2008; IEC 60598-2-3:2002; IEC 62031:2008; IEC 62471:2008; IES LM-80; IEC 61347-1:2008; IEC 61347-2-13:2006; IEC 55015:2006 + A1:2007 + A2:2009; IEC 61547:2009; IEC 61000-3-2:2006 + A1:2009 + A2:2009; IEC 61000-3-3:2008; IEC 61000-4-2,3,4,5,6,8,11; UL 8750;

The Retrofit Series offers solutions of up to 80W of power, allowing its easy integration in classic streetlights and urban luminaires, which makes it the simplest and most economical alternative for the adaptation to LED technology.

Its aluminum structure and its high degree of watertightness and protection against impacts make it an anti-vandalism and durable product, guaranteeing a useful life of the components of more than 100,000 hours of operation. It is usually installed in classic ornamental lanterns, but it can also be adapted to urban and pedestrian style luminaires.

This kit offers multiple lighting packages, with a wide range of photometric distributions and operating currents. Likewise, the closure of the optical compartment offers two different types of finishes, transparent or satin. The former guarantees maximum efficiency in lm/W and the latter significantly improves the visual comfort of pedestrians and drivers, giving this lantern an element of extraordinary personality, unique in the market.



RETROFIT

RETROFIT*

| | |
|-----------------------|------------------------------------|
| Structure | Aluminum injection |
| Diffuser | Polycarbonate/tempered glass |
| Dimensions and weight | Tailor-made to existing lantern |
| Anchoring systems | Supported, bolted, suspended, etc. |
| Gradual inclination | Optional |
| Degree of protection | IP66, IK10 |
| Warranty | 5/7/10 years |
| Certification | CE; RoHS |
| Safety class | I/II |

SPECIFICATIONS

OPTIONAL CONTROL SYSTEMS

Programmable regulation of up to 8 levels
 Time programming module
 (35 programs | reprogrammable from CM | winter-summer distinction)
 Point to point remote management RFLight₂
 DALI2/D4i, 1 -10V
 CLO (constant light level)
 Dimming at the head-end
 Control line dimming
 Photocell
 Socket NEMA 7 / Zhaga book 18
 Others: PLC, GPRS, 3G, NFC, NFC, Bluetooth, Narrow Band 5G

FEATURES*

| | |
|-------------------|--|
| Power | 10W-80W |
| Efficiency lm/W | Up to 170 lm/W |
| Input voltage | 90-305 V / ~ 50-60Hz (depending on model) |
| Power supply | PF > 0.95, Efficiency > 88% (depending on model) |
| Lifetime | >100,000 hours (L90B10) |
| LED Type | Cree®, Nichia®, Osram® |
| Color temperature | 1,800 K - 6,000 K / PC-Amber |
| Minimum CRI | 70/80 |
| FHS | 0% |

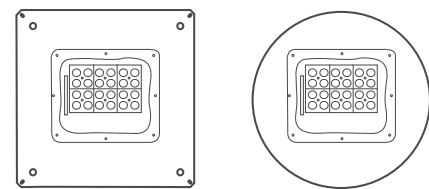

custom dimensions

VERSIONS*

| | ECO | STANDARD | PREMIUM | |
|-------------------------------|-----|----------|---------|---|
| OVERVOLTAGE PROTECTION | | | | ● Included ○ Optional ✗ Not available |
| 10 kV (en f. alim.) | ● | ✗ | ✗ | |
| 10 kV (SPD ext.) | ✗ | ● | ● | |
| 20 kV (SPD ext.) | ✗ | ○ | ○ | |
| REGULATION | | | | |
| 8 Levels | ● | ● | ✗ | |
| MPH (reprogrammable) | ✗ | ○ | ● | |
| OPERATING CURRENT | | | | |
| 500 mA | ○ | ○ | ● | |
| 700 mA | ○ | ● | ○ | |
| 1000 mA | ● | ○ | ○ | |

OPTICAL BLOCK

(Consult for more optical options)



ROAD I

Recommended distribution on tracks with extreme spacings up to 6 times the pole height

ROAD II

Recommended layout for roadways with a track width similar to the height of the pole

ROAD III

Recommended layout for roadways with up to two lanes with spacings up to 4 times the pole height.

ROAD IV

Recommended distribution on tracks with high clearances of up to 5 times the height of the pole

URBAN 360

Recommended distribution for medium-height omnidirectional lighting, such as parks and squares

* Specifications are subject to change



PRINCIPALITY OF ASTURIAS
LASTRES CITY COUNCIL (ASTURIAS)
RETROFIT installation of HispaLED

PROJECTORS



PORTO S/M



Sports areas



Monument lighting



Stations and parking



Tunnels



Logistics platforms and industrial areas



Parks, gardens and monumental areas

PORTOS/MHISPALED





Simple and functional LED floodlight for outdoor lighting

ROBUSTNESS AND FUNCTIONALITY

The Porto series floodlights are a simple and versatile solution for outdoor lighting applications, tunnels, parking lots, sports areas or ornamental lighting.

Its robust design and easy adaptation make it a multi-purpose projector that provides cost-effective and optimized solutions in scenarios that require the use of intermediate powers.



The Porto floodlight offers solutions of up to 400W of power, guaranteeing optimum results in a multitude of scenarios, such as sports areas, tunnel lighting, parking lots, logistics platforms, industrial areas or ornamental lighting.

Its robust design, with die-cast aluminum structure and finned cover, and a high degree of tightness and impact protection, guarantees high reliability and durability over time. It is suitable for post-top or side-entry mounting, allowing tilt adjustment to adapt perfectly to the lighting needs of each track. It offers multiple lighting packages, with a wide range of photometric distributions, operating currents and dimming possibilities.

TECHNICAL DATA SHEET

CE; RoHS; EN 60598-1:2009 + A11:2009; EN 60598-2-5; EN 62031:2009 + A1:2011; EN 62471:2008; IES LM-80; EN 61347-1:2008; EN 61347-2-13:2006; EN 55015:2006 + A1:2007 + A2:2009; EN 61547:2009; EN 61000-3-2:2006 + A1:2009 + A2:2009; EN 61000-3-3:2008; EN 61000-4-2,3,4,5,6,8,11; UL 8750; IEC 60598-1:2008; IEC 60598-2-3:2002; IEC 62031:2008; IEC 62471:2008; IES LM-80; IEC 61347-1:2008; IEC 61347-2-13:2006; IEC 55015:2006; + A1:2007 + A2:2009; IEC 61547:2009; IEC 61000-3:2006; A1:2009 + A2:2009; IEC 61000-3-3:2008; IEC 6100-4-2,3,4,5,6,8,11; UL 8750;

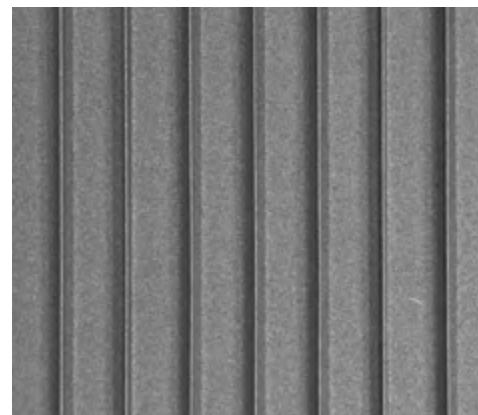

TECHNICAL DATA SHEET

PORTO S/M

PROY. PORTO S/M

SPECIFICATIONS

| | |
|-----------------------|---|
| Structure | Aluminum injection |
| Diffuser | Tempered glass/polycarbonate |
| Dimensions and weight | S: 420x224x60 mm / 7 Kg M: 535x255x75 mm / 11 Kg |
| Anchoring systems | Projector support (swivel angle marked on the bracket) |
| Degree of protection | IP66, IK08, IK10 optional |
| Warranty | 5/7/10 years |
| Certification | CE; RoHS |
| Safety class | I/II |

OPTIONAL CONTROL SYSTEMS

Programmable regulation of up to 8 levels
 Time programming module
 (35 programs | reprogrammable from CM | winter-summer distinction)
 Point to point remote management RFLight₂
 DALI2/D4i, 1 -10V
 CLO (constant light level)
 Dimming at the head-end
 Control line dimming
 Photocell
 Socket NEMA 7 / Zhaga book 18
 Others: PLC, GPRS, 3G, NFC, NFC, Bluetooth, Narrow Band 5G

FEATURES*

| | |
|-------------------|--|
| Power | S: 10W-200W M: 140W-400W |
| Efficiency lm/W | Up to 170 lm/W |
| Input voltage | 90-305 V / ~ 50-60Hz (depending on model) |
| Power supply | PF > 0.95, Efficiency > 88% (depending on model) |
| Lifetime | >100,000 hours (L90B10) |
| LED Type | Cree®, Nichia®, Osram® |
| Color temperature | 1,800 K - 6,000 K / PC-Amber |
| Minimum CRI | 70/80 |
| FHS | 0% |

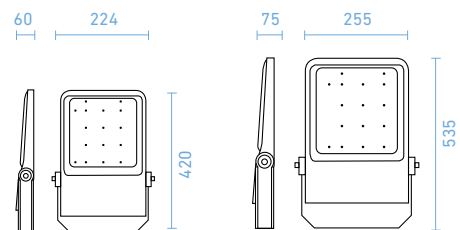

VERSIONS*

ECO

STANDARD

PREMIUM

- Included
- Optional
- ✗ Not available

OVERVOLTAGE PROTECTION

| | | | |
|---------------------|---|---|---|
| 10 kV (en f. alim.) | ● | ✗ | ✗ |
| 10 kV (SPD ext.) | ✗ | ● | ● |
| 20 kV (SPD ext.) | ✗ | ○ | ○ |

REGULATION

| | | | |
|----------------------|---|---|---|
| 8 Levels | ● | ● | ✗ |
| MPH (reprogrammable) | ✗ | ○ | ● |

OPERATING CURRENT

| | | | |
|---------|---|---|---|
| 500 mA | ○ | ○ | ● |
| 700 mA | ○ | ● | ○ |
| 1000 mA | ● | ○ | ○ |

OPTICAL BLOCK

(Consult for more optical options)

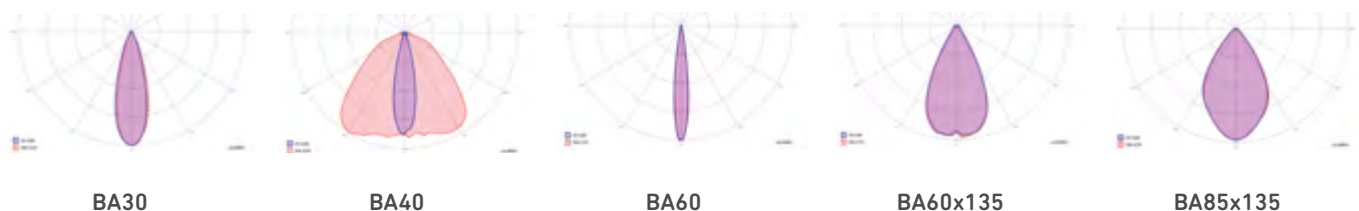

* Specifications are subject to change



GALICIA
TUNNEL (A CORUÑA)
Installation of Porto projectors by Hispaled

PROJECTORS



MERCURY



Sports areas



Lighting of monuments



Stations and parking



Tunnels



Logistics platforms and industrial areas



Parks, gardens and monumental spaces

MERCURYHISPALED





High quality LED floodlight for outdoor lighting

POWER AND VERSATILITY

The Mercury series floodlights offer a multifunctional solution, valid for outdoor lighting applications, tunnels, parking lots, sports areas or ornamental lighting.

Its wide diversity of powers, sizes and configurations makes this projector a resource of enormous versatility, offering perfectly optimized solutions for every type of scenario.



TECHNICAL DATA SHEET

CE; RoHS; EN 60598-1:2009 + A11:2009; EN 60598-2-5; EN 62031:2009 + A1:2011; EN 62471:2008; IES LM-80; EN 61347-1:2008; EN 61347-2-13:2006; EN 55015:2006 + A1:2007 + A2:2009; EN 61547:2009; EN 61000-3-2:2006 + A1:2009 + A2:2009; EN 61000-3-3:2008; EN 61000-4-2,3,4,5,6,8,11; UL 8750; IEC 60598-1:2008; IEC 60598-2-3:2002; IEC 62031:2008; IEC 62471:2008; IES LM-80; IEC 61347-1:2008; IEC 61347-2-13:2006; IEC 55015:2006; + A1:2007 + A2:2009; IEC 61547:2009; IEC 61000-3:2006; A1:2009 + A2:2009; IEC 61000-3-3:2008; IEC 6100-4-2,3,4,5,6,8,11; UL 8750;

The Mercury Series offers solutions up to 1200W of power, guaranteeing optimal lighting results in multiple scenarios such as sports areas such as sports areas, parking lots, industrial areas, tunnels, logistic platforms or ornamental lighting.

Its robust design, with die-cast aluminum structure and finned heatsink, as well as a high degree of tightness and impact protection, ensures high reliability and durability over time.

It is suitable for mounting by means of a swiveling strip, allowing tilt adjustment to adapt perfectly to the lighting needs of each stage. It offers multiple lighting packages, with a wide range of photometric distributions, operating currents and dimming possibilities.

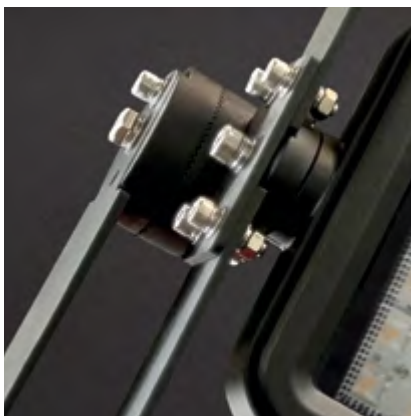
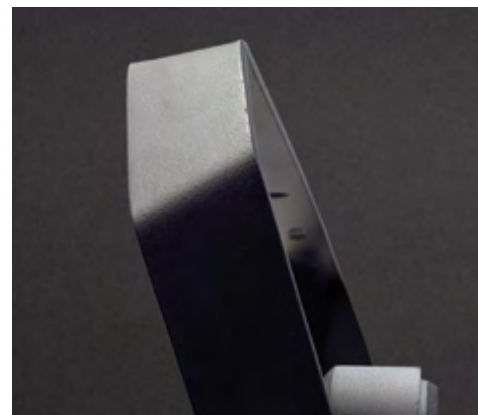
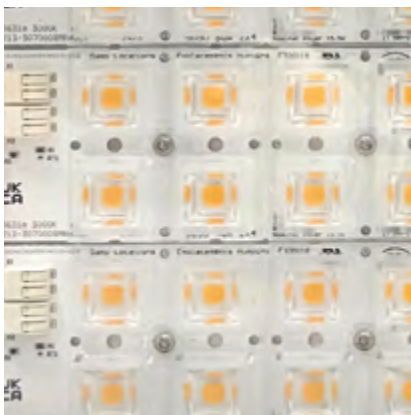

TECHNICAL DATA SHEET

MERCURY

MERCURY*

SPECIFICATIONS

| | |
|-----------------------|---|
| Structure | Aluminum injection |
| Diffuser | Tempered glass |
| Dimensions and weight | 785 x (220/450/680) x 130 mm 14/28/42 kg |
| Anchoring systems | Arm with 0 to 180° rotation |
| Degree of protection | IP66, IK08, Optional IK10 |
| Warranty | 5/7/10 years |
| Certification | CE; RoHS |
| Safety class | I/II |

OPTIONAL CONTROL SYSTEMS

Programmable regulation up to 5 levels
 Time programming module
 (35 programs | reprogrammable from CM | winter-summer distinction)
 Point to point remote management RFLight₂
 DALI2/D4i, 1 -10V
 CLO (constant light level)
 Dimming at the head-end
 Control line dimming
 Photocell
 Socket NEMA 7 / Zhaga book 18
 Others: PLC, GPRS, 3G, NFC, NFC, Bluetooth, Narrow Band 5G

FEATURES*

| | |
|-------------------|---|
| Power | 100W-1200W |
| Efficiency lm/W | Up to 170 lm/W |
| Input voltage | 90-305 V / ~ 50-60Hz (depending on model) |
| Power supply | PF > 0.95, Efficiency > 88% (depending on model) |
| Lifetime | >100,000 hours (L90B10) |
| LED Type | Cree®, Nichia®, Osram® |
| Color temperature | 1,800 K - 6,000 K / PC-Amber |
| Minimum CRI | 70/80 |
| FHS | 0% |

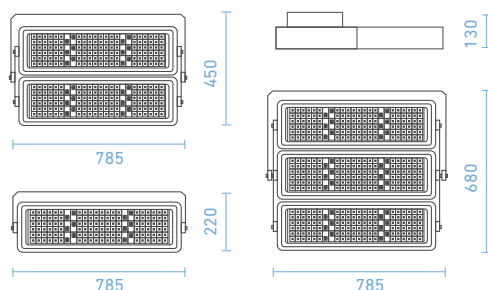

VERSIONS*

ECO

STANDARD

PREMIUM

- Included
- Optional
- ✗ Not available

OVERVOLTAGE PROTECTION

| | | | |
|---------------------|---|---|---|
| 10 kV (en f. alim.) | ● | ✗ | ✗ |
| 10 kV (SPD ext.) | ✗ | ● | ● |
| 20 kV (SPD ext.) | ✗ | ○ | ○ |

REGULATION

| | | | |
|----------------------|---|---|---|
| 8 Levels | ● | ✗ | ✗ |
| MPH (reprogrammable) | ✗ | ● | ● |

OPERATING CURRENT

| | | | |
|---------|---|---|---|
| 500 mA | ○ | ○ | ● |
| 700 mA | ○ | ● | ○ |
| 1000 mA | ● | ○ | ○ |

OPTICAL BLOCK

(Consult for more optical options)

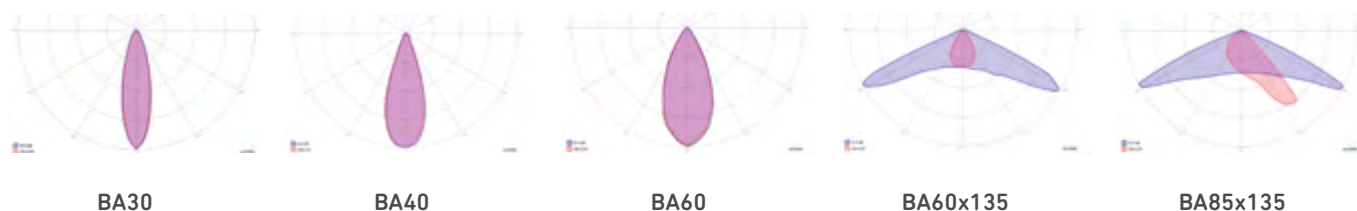

* Specifications are subject to change



ANDALUSIA
SOCCER FIELD (ALMERIA)
Installation of Hispaled Mercury floodlights

PROJECTORS



PRISMA



Sports areas



Lighting of monuments



Stations and parking



Tunnels



Logistics platforms and industrial areas



Parks, gardens and monumental spaces

PRISMASHISPALED





High quality LED floodlight for outdoor lighting

POWER AND VERSATILITY

The Prisma series floodlights are a multifunctional solution, valid for outdoor lighting applications, tunnels, parking lots, sports areas or ornamental lighting.

Its wide diversity of powers, sizes and configurations makes this projector a resource of enormous versatility, offering perfectly optimized solutions for every type of scenario.



TECHNICAL DATA SHEET

CE; RoHS; EN 60598-1:2009 + A1:2009; EN 60598-2-3:2003 + Corr:2005 + A1:2011; EN 62031:2009 + A1:2011; EN 62471:2008; IES LM-80; EN 61347-1:2008; EN 61347-2-13:2006; EN 55015:2006 + A1:2007 + A2:2009; EN 61547:2009; EN 61000-3-2:2006 + A1:2009 + A2:2009; EN 61000-3-3:2008; EN 61000-4-2,3,4,5,6,8,11; UL 8750; IEC 60598-1:2008; IEC 60598-2-3:2002; IEC 62031:2008; IEC 62471:2008; IES LM-80; IEC 61347-1:2008; IEC 61347-2-13:2006; IEC 55015:2006; + A1:2007 + A2:2009; IEC 61547:2009; IEC 61000-3:2006; A1:2009 + A2:2009; IEC 61000-3-3:2008; IEC 6100-4-2,3,4,5,6,8,11; UL 8750;

The Prisma Series offers solutions of up to 1500W of power, guaranteeing optimum lighting results in a multitude of scenarios, such as sports areas, tunnel lighting, parking lots, logistics platforms, industrial areas or ornamental lighting.

Its robust design, with die-cast aluminum structure and finned heatsink, as well as a high degree of tightness and impact protection, guarantees high reliability and durability over time.

It is suitable for mounting by means of a swiveling strip, allowing tilt adjustment to adapt perfectly to the lighting needs of each stage. It offers multiple lighting packages, with a wide range of photometric distributions, operating currents and dimming possibilities.

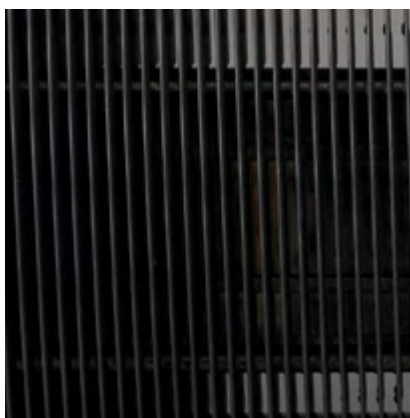
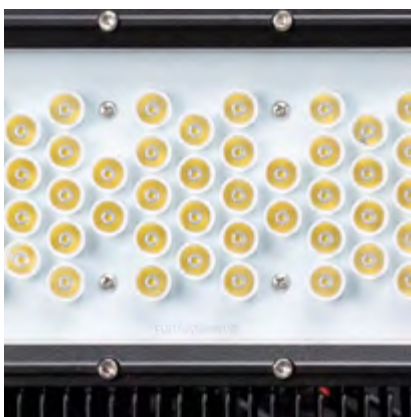

TECHNICAL DATA SHEET

PRISMA

PRISMA*

SPECIFICATIONS

| | |
|-----------------------|-----------------------------|
| Structure | Aluminum injection |
| Diffuser | Tempered glass |
| Dimensions and weight | According to model |
| Anchoring systems | Arm with 0 to 180° rotation |
| Degree of protection | IP65, IK08 |
| Warranty | 5/7/10 years |
| Certification | CE; RoHS |
| Safety class | I/II |

OPTIONAL CONTROL SYSTEMS

Programmable regulation up to 5 levels
 Time programming module
 (35 programs | reprogrammable from CM | winter-summer distinction)
 Point to point remote management RFLight₂
 DALI2/D4i, 1 -10V
 CLO (constant light level)
 Dimming at the head-end
 Control line dimming
 Photocell
 Socket NEMA 7 / Zhaga book 18
 Others: PLC, GPRS, 3G, NFC, NFC, Bluetooth, Narrow Band 5G

FEATURES*

| | |
|-------------------|--|
| Power | 60W-1500W |
| Efficiency lm/W | Up to 170 lm/W |
| Input voltage | 90-305 V / ~ 50-60Hz (depending on model) |
| Power supply | PF > 0.95, Efficiency > 88% (depending on model) |
| Lifetime | >100,000 hours (L90B10) |
| LED Type | Cree®, Nichia®, Osram® |
| Color temperature | 1,800 K - 6,000 K / PC-Amber |
| Minimum CRI | 70/80 |
| FHS | 0% |

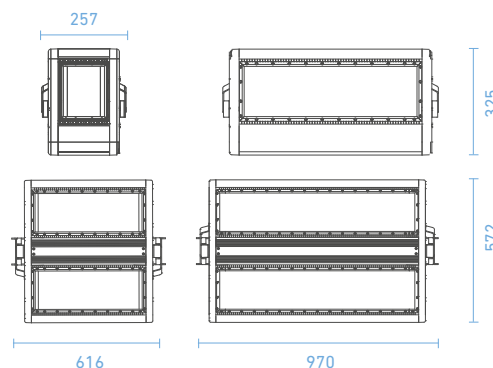

VERSIONS*

ECO

STANDARD

PREMIUM

- Included
- Optional
- ✗ Not available

OVERVOLTAGE PROTECTION

| | | | |
|---------------------|---|---|---|
| 10 kV (en f. alim.) | ● | ✗ | ✗ |
| 10 kV (SPD ext.) | ✗ | ● | ● |
| 20 kV (SPD ext.) | ✗ | ○ | ○ |

REGULATION

| | | | |
|----------------------|---|---|---|
| 8 Levels | ● | ✗ | ✗ |
| MPH (reprogrammable) | ✗ | ● | ● |

OPERATING CURRENT

| | | | |
|---------|---|---|---|
| 500 mA | ○ | ○ | ● |
| 700 mA | ○ | ● | ○ |
| 1000 mA | ● | ○ | ○ |

OPTICAL BLOCK

(Consult for more optical options)

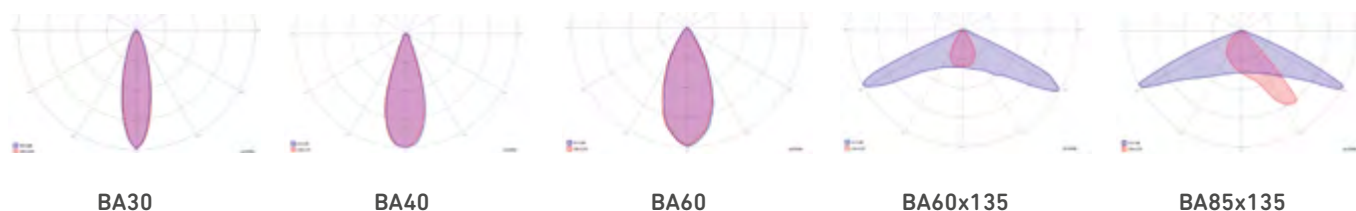

* Specifications are subject to change



GALICIA
SPORTS CENTER OF ORDES (A CORUÑA)
Installation of Hispaled Prisma projectors

PROJECTORS



PROJECTOR NAVIA S/M/X



Zonas deportivas



Sports areas



Stations and parking



Tunnels



Logistics platforms and industrial areas



Parks, gardens and pedestrian spaces

PROYECTOR NAVIAS/M/XHISPALED

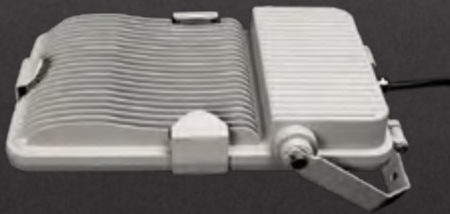
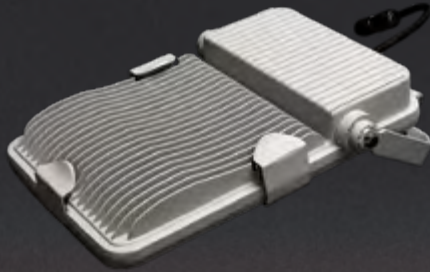



Simple and functional LED floodlight for outdoor lighting

ROBUSTNESS AND FUNCTIONALITY

The Navia series floodlights are a simple and versatile solution for outdoor lighting applications, tunnels, parking lots, sports areas or ornamental lighting.

Its robust design and easy adaptation make it a multi-purpose projector that provides cost-effective and optimized solutions in scenarios that require the use of intermediate powers.



TECHNICAL DATA SHEET

CE; RoHS; EN 60598-1:2009 + A11:2009; EN 60598-2-3:2003 + Corr:2005 + A1:2011; EN 62031:2009 + A1:2011; EN 62471:2008; IES LM-80; EN 61347-1:2008; EN 61347-2-13:2006; EN 55015:2006 + A1:2007 + A2:2009; EN 61547:2009; EN 61000-3-2:2006 + A1:2009 + A2:2009; EN 61000-3-3:2008; EN 61000-4-2,3,4,5,6,8,11; UL 8750; IEC 60598-1:2008; IEC 60598-2-3:2002; IEC 62031:2008; IEC 62471:2008; IES LM-80; IEC 61347-1:2008; IEC 61347-2-13:2006; IEC 55015:2006; + A1:2007 + A2:2009; IEC 61547:2009; IEC 61000-3:2006; A1:2009 + A2:2009; IEC 61000-3-3:2008; IEC 6100-4-2,3,4,5,6,8,11; UL 8750;

The Navia floodlight offers solutions of up to 160W of power, guaranteeing optimum results in a multitude of scenarios, such as sports areas, tunnel lighting, parking lots, logistics platforms, industrial areas or ornamental lighting.

Its robust design, with die-cast aluminum structure and finned cover, and a high degree of tightness and impact protection, guarantees high reliability and durability over time. It is suitable for post-top or side-entry mounting, allowing tilt adjustment to adapt perfectly to the lighting needs of each track. Its tool-free opening facilitates height mounting for the installer. It offers multiple lighting packages, with a wide range of photometric distributions, operating currents and dimming possibilities.

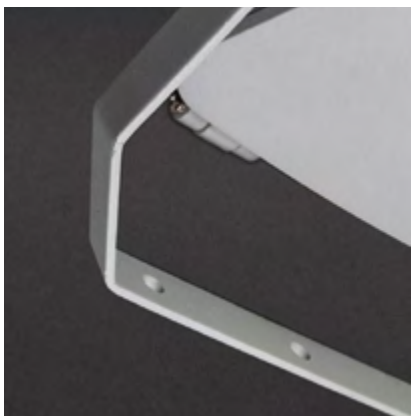

TECHNICAL DATA SHEET

PROYECTOR NAVIA S/M/X

PROY. NAVIA S/M/X*

SPECIFICATIONS

| | |
|-----------------------|--|
| Structure | Aluminum injection |
| Diffuser | Tempered glass/polycarbonate |
| Dimensions and weight | S: 339x220x58 mm / 4 Kg M: 430x250x65 mm / 6 Kg X: 566x322x81 mm / 10 Kg |
| Anchoring systems | Projector support |
| Degree of protection | IP66, IK08 (IK10 optional) |
| Warranty | 5/7/10 years |
| Certification | CE; RoHS |
| Safety class | I/II |
| Opening | Tool-free, with optional electrical disconnection. |

OPTIONAL CONTROL SYSTEMS

Programmable regulation of up to 8 levels
 Time programming module (35 programs | reprogrammable from CM | winter-summer distinction)
 (35 programs | reprogrammable from CM | winter-summer distinction)
 Point to point remote management RFLight2
 DALI2/D4i, 1 -10V
 CLO (constant light level)
 Dimming at the head-end
 Control line dimming
 Photocell
 Socket NEMA 7 / Zhaga book 18
 Others: PLC, GPRS, 3G, NFC, NFC, Bluetooth, Narrow Band 5G

FEATURES*

| | |
|-------------------|--|
| Power | 10W-160W |
| Efficiency lm/W | Up to 170 lm/W |
| Input voltage | 90-305 V / ~ 50-60Hz (depending on model) |
| Power supply | PF > 0.95, Efficiency > 88% (depending on model) |
| Lifetime | >100,000 hours (L90B10) |
| LED Type | Cree®, Nichia®, Osram® |
| Color temperature | 1,800 K - 6,000 K / PC-Amber |
| Minimum CRI | 70/80 |
| FHS | 0% |

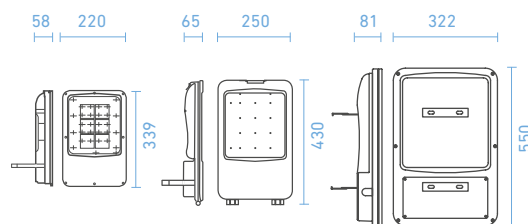

VERSIONS*

ECO

STANDARD

PREMIUM

- Included
- Optional
- ✗ Not available

OVERVOLTAGE PROTECTION

| | | | |
|---------------------|---|---|---|
| 10 kV (en f. alim.) | ● | ✗ | ✗ |
| 10 kV (SPD ext.) | ✗ | ● | ● |
| 20 kV (SPD ext.) | ✗ | ○ | ○ |

REGULATION

| | | | |
|----------------------|---|---|---|
| 8 Levels | ● | ● | ✗ |
| MPH (reprogrammable) | ✗ | ○ | ● |

| | | | |
|---------|---|---|---|
| 500 mA | ○ | ○ | ● |
| 700 mA | ○ | ● | ○ |
| 1000 mA | ● | ○ | ○ |

OPTICAL BLOCK

(Consult for more optical options)

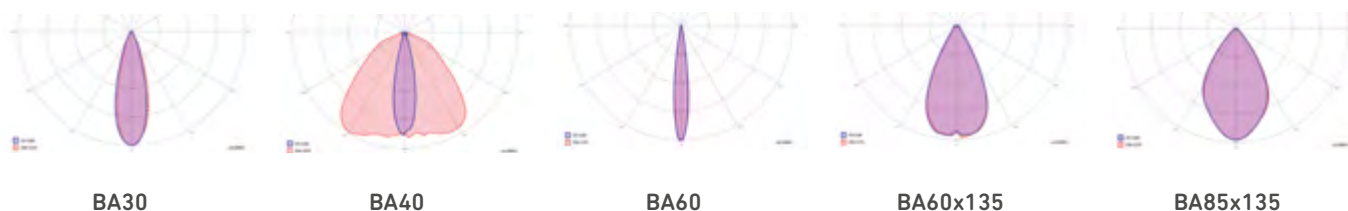

* Specifications are subject to change



GALICIA
SPORTS CENTER OF ORDES (A CORUÑA)
Installation of NAVIA projectors by Hispaled

INDUSTRIALS



LISA



Service stations



Marquees



Industrial areas

LISAHISPALED





Recessed luminaire with LED technology, ideal for service stations.

FUNCTIONALITY AND EFFICIENCY

Hispaled's Lisa series is a range of recessed floodlights, offering an ideal solution for service station lighting.

Quickly amortized product that allows the renovation of lighting in all types of canopies, replacing high-power discharge technologies and guaranteeing greater energy efficiency.



The Lisa Series offers solutions of up to 200W of power, guaranteeing maximum efficiency in the lighting of service stations, canopies and industrial spaces.

Its robust design, with die-cast aluminum structure and finned heatsink, as well as a high degree of tightness and impact protection, ensures high reliability and durability over time.

It is suitable for mounting by means of a swiveling strip, allowing for tilt adjustment to adapt perfectly to the lighting needs of each stage.

This luminaire offers multiple lighting packages, with a wide range of photometric distributions, operating currents and dimming possibilities.

TECHNICAL DATA SHEET

CE; RoHS; EN 60598-1:2009 + A11:2009; EN 60598-2-3:2003 + Corr:2005 + A1:2011; EN 62031:2009 + A1:2011; EN 62471:2008; IES LM-80; EN 61347-1:2008; EN 61347-2-13:2006; EN 62384:2006/A1:2010; EN 55015:2006 + A1:2007 + A2:2009; EN 61547:2009; EN 61000-3-2:2006 + A1:2009 + A2:2009; EN 61000-3-3:2008; EN 61000-4-2,3,4,5,6,8,11, UL 8750; IEC 60598-1:2008; IEC 60598-2-3:2002; IEC 62031:2008; IEC 62471:2008; IES LM-80; IEC 61347-1:2008; IEC 61347-2-13:2006; IEC 55015:2006 + A1:2007 + A2:2009; IEC 61547:2009; IEC 61000-3-2:2006 + A1:2009 + A2:2009; IEC 61000-3-3:2008; IEC 61000-4-2,3,4,5,6,8,11; UL 8750;

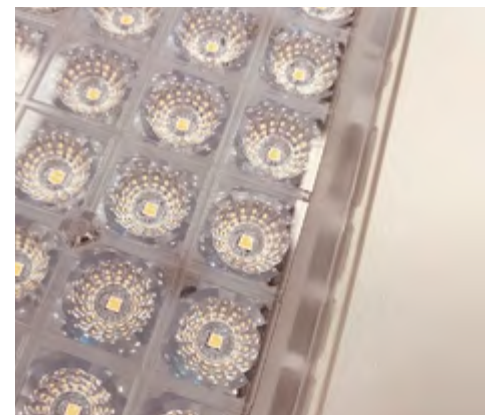
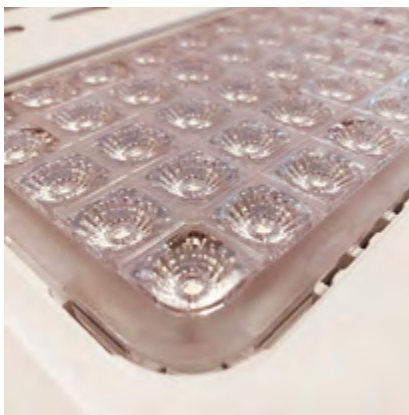

TECHNICAL DATA SHEET

LISA

LISA*

SPECIFICATIONS

| | |
|-----------------------|-------------------------------|
| Structure | Aluminum injection |
| Diffuser | Tempered glass |
| Dimensions and weight | 400x400x140 mm / 7,6Kg |
| Anchoring systems | Configurable with accessories |
| Degree of protection | IP65, IK08 |
| Warranty | 5/7/10 years |
| Certification | CE; RoHS; |

OPTIONAL CONTROL SYSTEMS

Programmable regulation up to 5 levels
 Time programming module
 (35 programs | reprogrammable from CM | winter-summer distinction)
 Point to point remote management RFLight₂
 DALI2/D4i, 1 -10V
 CLO (constant light level)
 Dimming at the head-end
 Control line dimming
 Photocell
 Socket NEMA 7 / Zhaga book 18
 Others: PLC, GPRS, 3G, NFC, NFC, Bluetooth, Narrow Band 5G

FEATURES*

| | |
|-------------------|--|
| Power | 50W-200W |
| Efficiency lm/W | Up to 170 lm/W |
| Input voltage | 90-305 V / ~ 50-60Hz (depending on model) |
| Power supply | PF > 0.95, Eficiencia > 88% (depending on model) |
| Lifetime | >100.000 hours (L90B10) |
| LED Type | Cree®, Nichia® |
| Color temperature | 1,800 K - 6,000 K / PC-Amber |
| Minimum CRI | 70/80 |
| FHS | 0% |

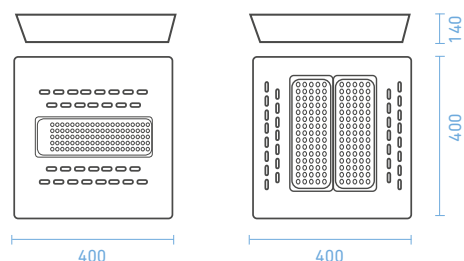

VERSIONS*

ECO

STANDARD

PREMIUM

- Included
- Optional
- ✗ Not available

OVERVOLTAGE PROTECTION

| | | | |
|---------------------|---|---|---|
| 10 kV (en f. alim.) | ● | ✗ | ✗ |
| 10 kV (SPD ext.) | ✗ | ● | ● |
| 20 kV (SPD ext.) | ✗ | ○ | ○ |

REGULATION

| | | | |
|----------------------|---|---|---|
| 8 Levels | ● | ✗ | ✗ |
| MPH (reprogrammable) | ✗ | ● | ● |
| | ✗ | ○ | ○ |

OPERATING CURRENT

| | | | |
|---------|---|---|---|
| 500 mA | ○ | ○ | ● |
| 700 mA | ○ | ● | ○ |
| 1000 mA | ● | ○ | ○ |

OPTICAL BLOCK

(Consult for more optical options)

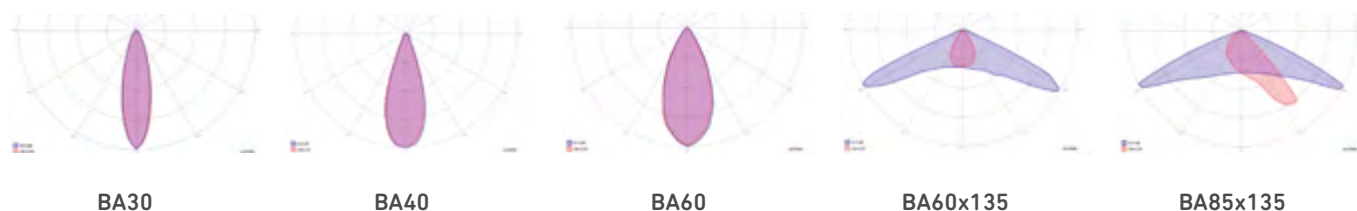

* Specifications are subject to change



CASTILLA Y LEÓN
GAS STATION IN CUÉLLAR (SEGOVIA)
Installation of Hispaled's LISA luminaires

INDUSTRIALS



FABRIK



Sports areas



Industrial areas

FABRIKHISPALED





Led bell for industrial lighting

EFFICIENCY AND COMFORT

Hispaled's Fabrik series is a wide range of LED hoods specifically designed for industrial lighting or indoor sports areas.

The main added values of this product are the great energy savings obtained by replacing high-power discharge lamps, and the improvement of visual comfort through the use of high CRI light sources.



The Fabrik Series offers solutions of up to 250W of power, guaranteeing maximum efficiency in the lighting of industrial spaces and indoor sports facilities.

Its robust design, with die-cast aluminum structure and finned heatsink, as well as a high degree of tightness and impact protection, ensures high reliability and durability over time.

It is suitable for mounting by means of a swiveling strip, allowing tilt adjustment to adapt perfectly to the lighting needs of each stage.

It offers multiple lighting packages, with a wide range of photometric distributions, operating currents and dimming possibilities.

TECHNICAL DATA SHEET

CE; RoHS; EN 60598-1:2009 + A11:2009; EN 60598-2-3:2003 + Corr:2005 + A1:2011; EN 62031:2009 + A1:2011; EN 62471:2008; IES LM-80; EN 61347-1:2008; EN 61347-2-13:2006; EN 62384:2006/A1:2010; EN 55015:2006 + A1:2007 + A2:2009; EN 61547:2009; EN 61000-3-2:2006 + A1:2009 + A2:2009; EN 61000-3-3:2008; EN 61000-4-2,3,4,5,6,8,11, UL 8750; IEC 60598-1:2008; IEC 60598-2-3:2002; IEC 62031:2008; IEC 62471:2008; IES LM-80; IEC 61347-1:2008; IEC 61347-2-13:2006; IEC 55015:2006 + A1:2007 + A2:2009; IEC 61547:2009; IEC 61000-3-2:2006 + A1:2009 + A2:2009; IEC 61000-3-3:2008; IEC 61000-4-2,3,4,5,6,8,11; UL 8750;



TECHNICAL DATA SHEET

FABRIK

FABRIK*

| | |
|-----------------------|-------------------------------|
| Structure | Aluminum injection |
| Diffuser | Tempered glass |
| Dimensions and weight | Depending on model |
| Anchoring systems | Configurable with accessories |
| Degree of protection | IP65, IK08 |
| Warranty | 5/7/10 years |
| Certification | CE; RoHS |
| Safety class | I/II |

SPECIFICATIONS

OPTIONAL CONTROL SYSTEMS

Programmable regulation up to 5 levels
 Time programming module
 (35 programs | reprogrammable from CM | winter-summer distinction)
 Point to point remote management RFLight₂
 DALI2/D4i, 1 -10V
 CLO (constant light level)
 Dimming at the head-end
 Control line dimming
 Photocell
 Socket NEMA 7 / Zhaga book 18
 Others: PLC, GPRS, 3G, NFC, NFC, Bluetooth, Narrow Band 5G

FEATURES*

| | |
|-------------------|--|
| Power | 60W-250W |
| Efficiency lm/W | Up to 170 lm/W |
| Input voltage | 90-305 V / ~ 50-60Hz (depending on model) |
| Power supply | PF > 0.95, Efficiency > 88% (depending on model) |
| Lifetime | >100,000 hours (L90B10) |
| LED Type | Cree®, Nichia®, Osram® |
| Color temperature | 1,800 K - 6,000 K / PC-Amber |
| Minimum CRI | 70/80 |
| FHS | 0% |

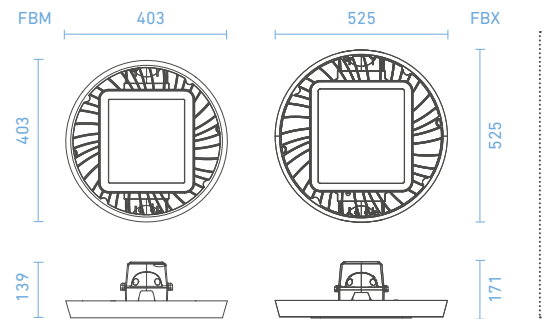

VERSIONS*

| | ECO | STANDARD | PREMIUM | |
|-------------------------------|-----|----------|---------|------------|
| OVERVOLTAGE PROTECTION | | | | |
| 10 kV (en f. alim.) | ● | × | × | ● Included |
| 10 kV (SPD ext.) | × | ● | ● | ○ Optional |
| 20 kV (SPD ext.) | × | ○ | ○ | × |
| REGULATION | | | | |
| 8 Levels | ● | × | × | |
| MPH (reprogrammable) | × | ● | ● | |
| OPERATING CURRENT | | | | |
| 500 mA | ○ | ○ | ● | |
| 700 mA | ○ | ● | ○ | |
| 1000 mA | ● | ○ | ○ | |

OPTICAL BLOCK

(Consult for more optical options)

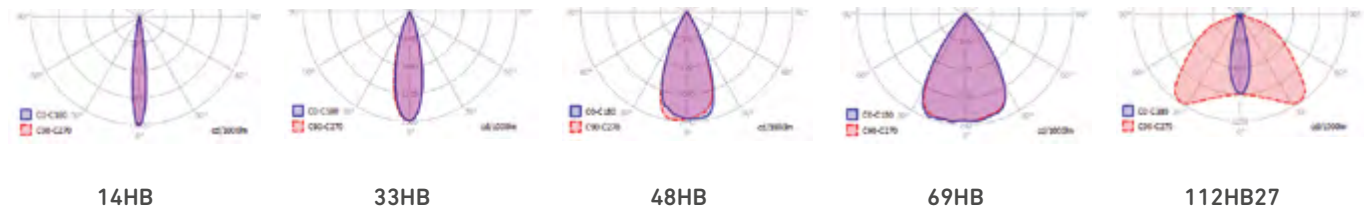

* Specifications are subject to change



GALICIA
SPORTS CENTER OF ORDES
Installation of FABRIK luminaires by Hispaled



A different vision

LIGHTING PROJECTS

Juan Carlos I Park
(Madrid)

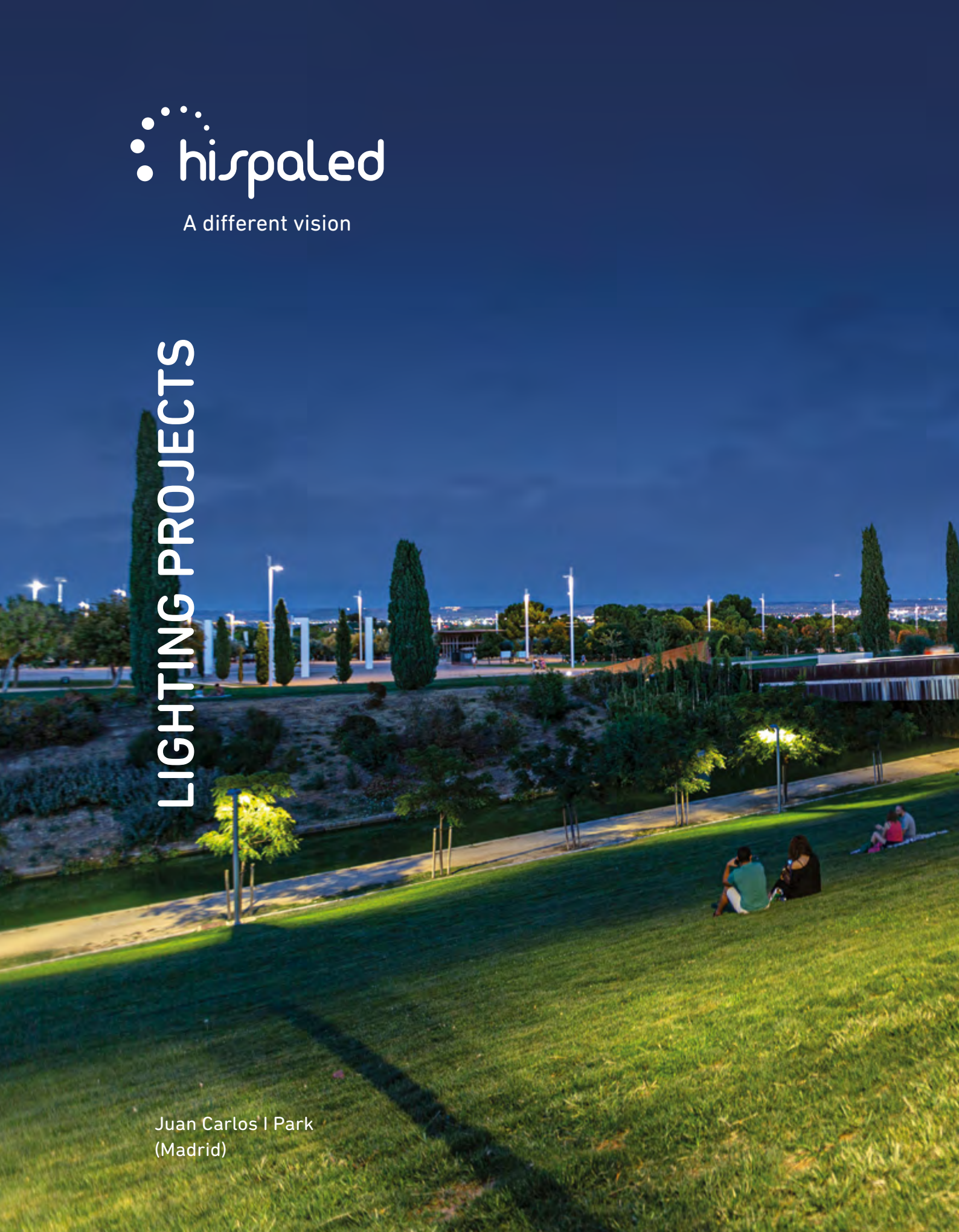





Lastres (Asturias)



Betanzos (Galicia)



Mijas (Málaga)



Ayllón (Segovia)

Castuera (Badajoz)



Quinta de los Molinos Park (Madrid)



Almodovar del Campo (Ciudad Real)



Antequera (Málaga)



Ecija (Sevilla)



Palma del Condado (Huelva)



Almagro (Ciudad Real)



Carrión de los Condes (Palencia)



Lerma (Burgos)



La Línea de la Concepción (Cádiz)



Gijón (Asturias)



Belorado (Burgos)



Alpedrete (Madrid)







Quinta de la Fuente del Berro Park
(Madrid)



RFLight₂



RFLIGHT₂ A different city





HISPALED's RFLight₂ is one of the most advanced remote management systems for public lighting in the market. From RFLight₂ Web you can control, through a simple and intuitive interface, both the luminaires and the Control Centers of any installation. With this, resources are efficiently used to the maximum, maintenance costs are reduced and a better quality of the municipality's lighting is guaranteed, with an individualized control of the lighting points and electrical panels.

- SYSTEM RFLIGHT₂**
- > Nodes for luminaire **Node RFLight₂**
 - > Header **RFLight₂ Header Panel Monitoring RFLight₂ Header**
 - > Gateway **RFLight₂ Gateway**
 - > Installation and Inventory App **RFLight₂ Geo**
 - > Web Lighting Management Platform **RFLight₂ Web**

RFLIGHT₂ ARCHITECTURE

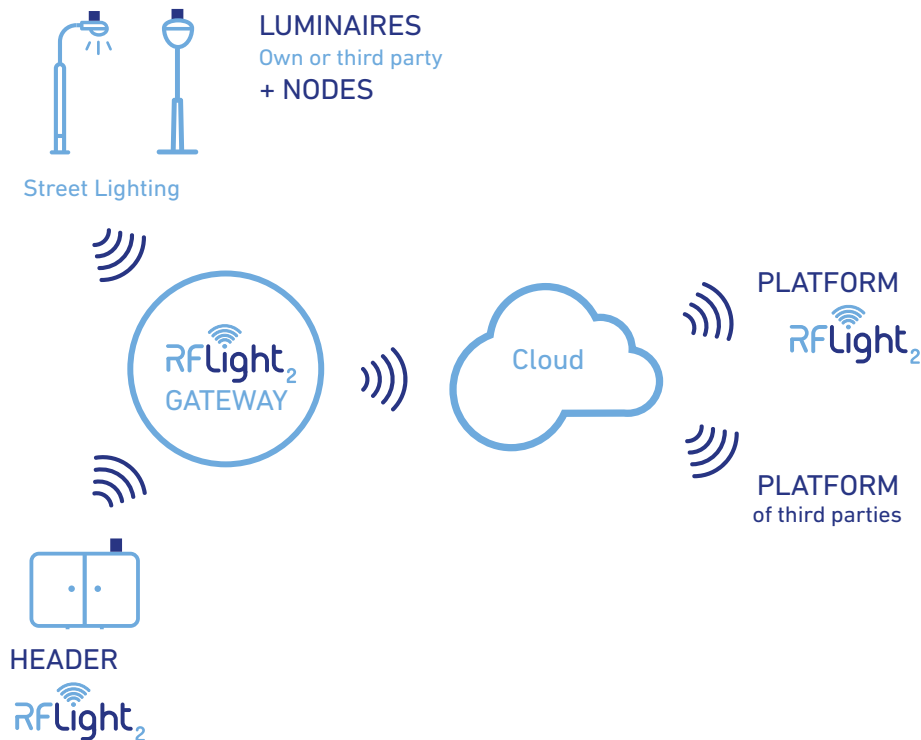

RFLight₂ allows the remote management of HISPALED luminaires, as well as those of other manufacturers.

Our open system can be integrated into any lighting management web platform.

RFLight₂ allows the remote management of control centers and luminaires, both from HISPALED and other manufacturers, and integrates with any web platform, proprietary or third party, from which to operate on the lighting panels and luminaires point to point, reporting information, allowing the comprehensive management and control of the lighting system.

“ RFLight2 is HispaLED’s connectivity solution for remote control and optimization of lighting networks through point-to-point remote management. ”

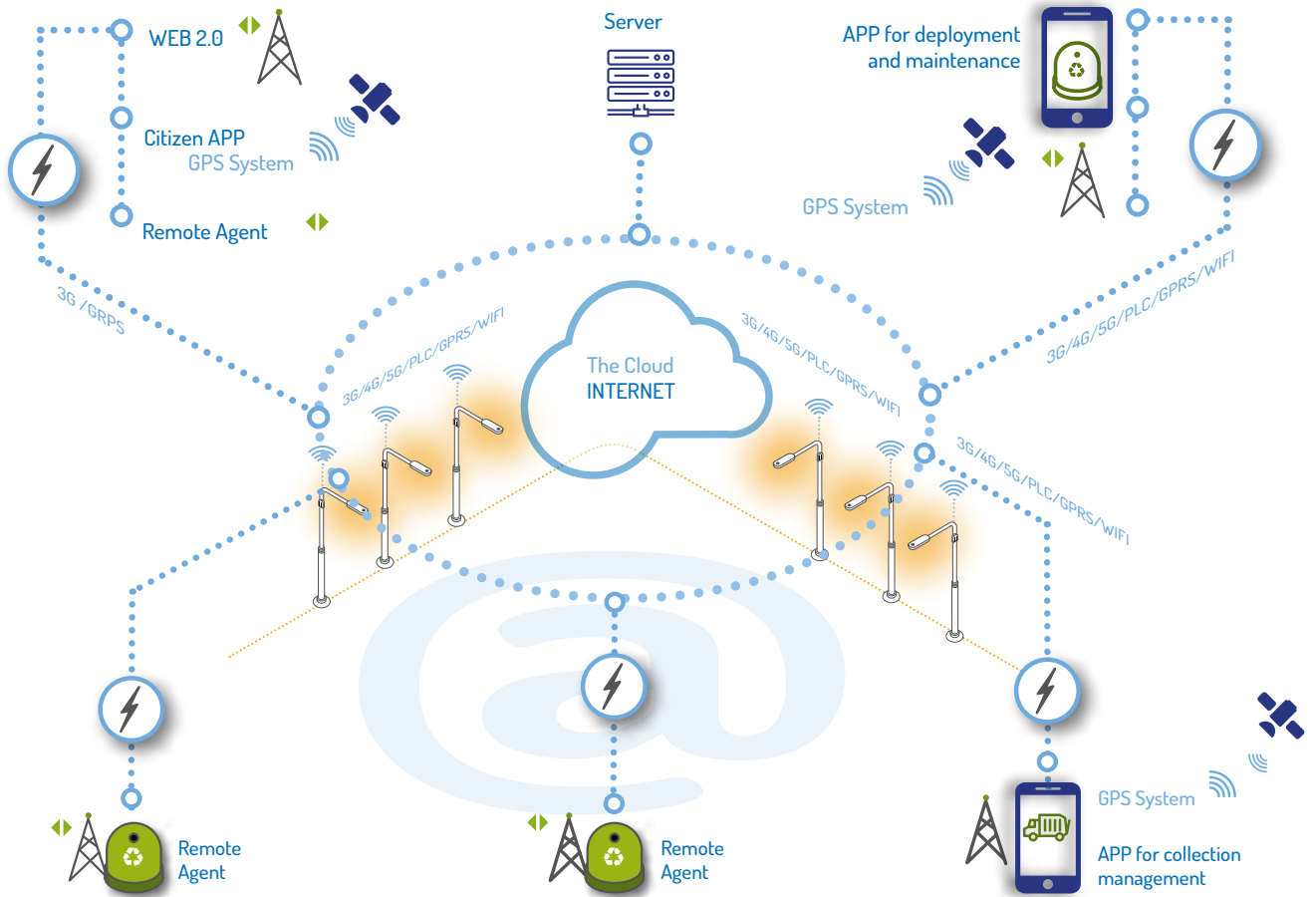

The mesh network formed by the luminaires serves as a communications platform for use in other citizen services such as: garbage collection, pollution measurement stations, park and garden irrigation systems, video surveillance cameras, parking lot management, etc.

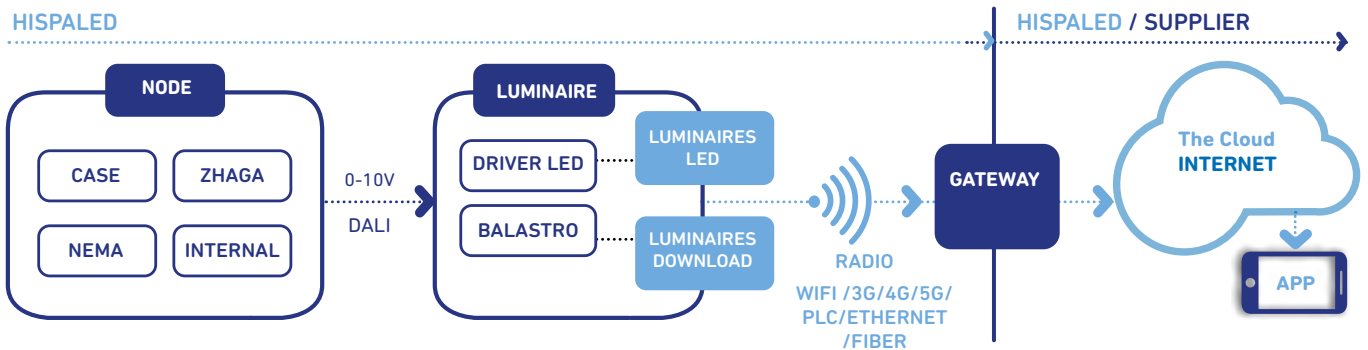

The luminaires form a communications network where each luminaire is a node in the network. Each of these nodes is capable of sending or receiving information to any point.

NODES THAT CAN BE INTEGRATED INTO ANY LIGHTING INSTALLATION
TECHNOLOGIES: RADIO FREQUENCY (LoRa) - NARROW BAND - GPRS - PLC

RFLIGHT₂ EXTERNAL NODES

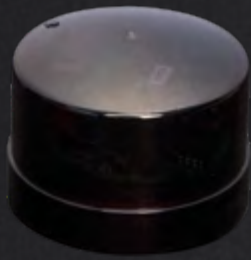

NEMA

The RFLight₂ NEMA external node is available in 5 and 7 pins. Compatible with the ANSI C136.41 standard, it is widely accepted for its compatibility with photocell type dimming equipment, which has been widely used throughout the world for decades. It is therefore one of the most widely used formats today.

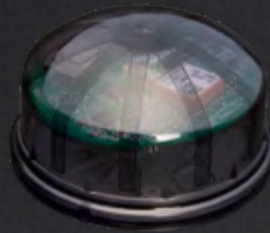

ZHAGA

The RFLight₂ ZHAGA external node, Book 18 specification, is the most current compatible format on the market, and possibly the most widely used in newly manufactured luminaires, due to its simplicity and specific design for the control of lighting equipment.



BOX

The RFLight₂ external node in Box format allows installation in any luminaire on the market. It is installed on the street light bracket by means of a clamp supplied with the product, and allows the power supply to be wired inside the luminaire, without the luminaire necessarily having any NEMA or ZHAGA receptacle.

FUNCTIONALITIES

- Luminaire uptime.
- Real consumption of the luminaire (DC or AC).
- Alarms/Notifications via email/SMS:
 - Luminaire failure (light source, LED driver/ballast, input current).
 - Consumption error (over or under).
 - Overheating.
- Date and time:
 - Stored in the node or synchronized by GPS.
- OTAP (Over the Air Programming) firmware update.
- Concentrator Device (AP) for every 500 to 1000 nodes.
- Communication with luminaires: via Radio (LoRa).
- Communication with the cloud via: GRPS/3G/4G/WiFi/Fiber/Ethernet.
- Integrable in third party WEB platforms, via public API.

- Luminaire uptime.
- Real consumption of the luminaire (DC or AC).
- Alarms/Notifications via email/SMS:
 - Luminaire failure (light source, LED driver/ballast, input current).
 - Consumption error (over or under).
 - Overheating.
- Date and time:
 - Stored in the node or synchronized by GPS.
- OTAP (Over the Air Programming) firmware update.
- Concentrator Device (AP) for every 500 to 1000 nodes.
- Communication with luminaires: via Radio (LoRa).
- Communication with the cloud via: GRPS/3G/4G/WiFi/Fiber/Ethernet.
- Integrable in third party WEB platforms, via public API.

- Luminaire uptime.
- Real consumption of the luminaire (DC or AC).
- Alarms/Notifications via email/SMS:
 - Luminaire failure (light source, LED driver/ballast, input current).
 - Consumption error (over or under).
 - Overheating.
- Date and time:
 - Stored in the node or synchronized by GPS.
- OTAP (Over the Air Programming) firmware update.
- Concentrator Device (AP) for every 500 to 1000 nodes.
- Communication with luminaires via Radio (LoRa).
- Communication with the cloud via: GRPS/3G/4G/WiFi/Fiber/Ethernet.
- Integrable with third-party WEB platforms, via public API.

Hispaled's RFLight₂ nodes for Public Lighting luminaires incorporate the latest communications technologies: Radio Frequency, Narrow Band, 3G/4G, PLC, etc... which allows us to adapt to any technical solution required by the municipality.

RFLIGHT₂ INTERNAL NODES



INTERNAL NODE

The RFLight₂ internal node is the compact version designed to be installed inside the luminaire. It is powered directly by 12-24VDC voltage. Being a radio system, it is necessary to install an antenna in the luminaire.

- Luminaire uptime.
- Actual consumption of the luminaire (DC or AC).
- Alarms/Notifications via email/SMS:
 - Luminaire failure (light source, LED driver/ballast, input current).
 - Consumption error (over or under).
 - Overheating.
- Date and time:
 - Stored in the node or synchronized by GPS.
- OTAP (Over the Air Programming) firmware update.
- Concentrator Device (AP) for every 500 to 1000 nodes.
- Communication with luminaires via Radio (LoRa).
- Communication with the cloud via:
 - GRPS/3G/4G/WiFi/Fiber/Ethernet.
- Integrable with third-party WEB platforms, via public API.

INTEGRATION NODES IN LUMINAIRE

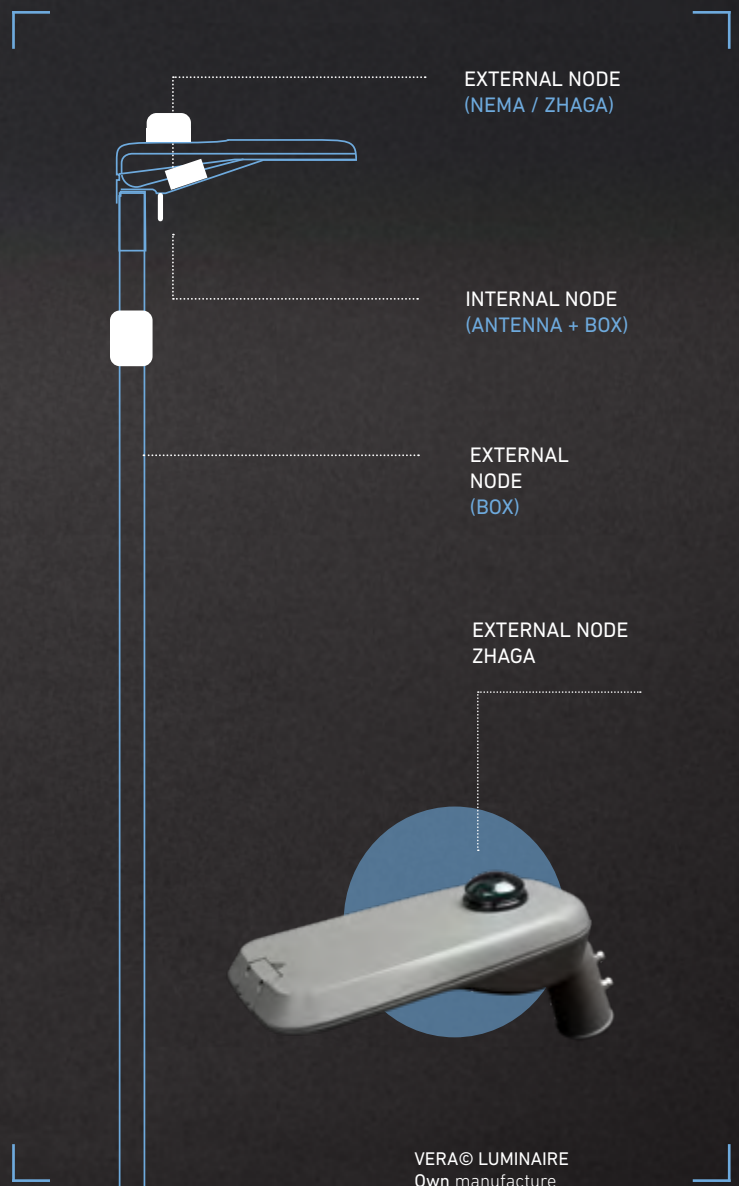

PROGRAMMING

- **ON AND OFF**
Allows you to program precise on/off schedules for electrical lines and circuits, optimizing energy consumption and improving operational efficiency.
- **SUNRISE AND SUNSET CALCULATION**
Automatically calculates sunrise (dawn) and sunset (dusk) times, allowing the lighting to be optimally adjusted according to available daylight.
- **AUTOMATIC WINTER-SUMMER AND SUMMER-WINTER TIME CHANGEOVER**
Automatically adjusts to daylight saving time, eliminating the need for manual intervention and ensuring continuity in the programming of electrical systems.
- **AUTOMATIC ADJUSTMENT BASED ON YOUR LOCATION**
Uses geolocation technology to automatically adjust your time based on the location of the Command Center, ensuring accurate synchronization with local time.
- **PROGRAMMING-INDEPENDENT RELAY MANAGEMENT**
Allows relays to be managed independently of the established schedule, providing greater flexibility and control over the operation of electrical systems.
- **PROFILE AND SCHEDULE MANAGEMENT**
Provides the ability to create and manage customized configuration profiles and schedules, adapting to the specific needs of each user and environment.

ALARMS

Users have the flexibility to configure alarms and warnings according to their specific needs.

- **PROGRAMMABLE ACCORDING TO ELECTRICAL PARAMETERS**
It offers the ability to program alarms and warnings in an intelligent way, using the electrical parameters of the power line. This feature allows early detection of potential problems and a proactive response to risk situations.
- **PROGRAMMABLE BASED ON EXTERNAL SENSORS**
It can integrate readings from external sensors, such as: temperature, presence, noise, etc. sensors. This expands its risk detection capacity and adaptability, allowing a more complete response to different situations.

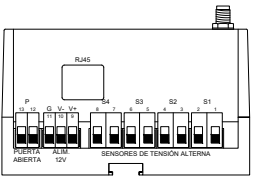
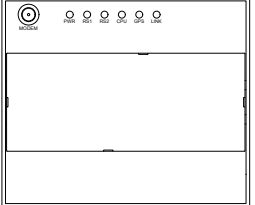
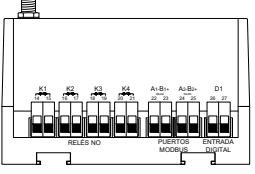
| | |
|--|---|
| <ul style="list-style-type: none"> • 4 AC voltage sensors |    <p>Bedside Equipment Model v01</p> |
| <ul style="list-style-type: none"> • 4 NO relay outputs | |
| <ul style="list-style-type: none"> • 2 digital inputs | |
| <ul style="list-style-type: none"> • 2 RS485 communication ports | |
| <ul style="list-style-type: none"> • 1 RJ45 ethernet port | |
| <ul style="list-style-type: none"> • 1 SMA female port | |
| <ul style="list-style-type: none"> • Communication via: <ul style="list-style-type: none"> • Ethernet – 100 Mbps • WiFi 4 – 600 Mbps – 2,4/5 GHz • Bluetooth 5.2 – 50Mbps – 2,4GHz • GPRS/3G/4G/NB/CAT-M – 900/1.800 MHz | |
| <ul style="list-style-type: none"> • Network analyzer for direct measurement (up to 65Aac) and direct measurement by current transformers. | |
| <ul style="list-style-type: none"> • 12Vdc power supply | |

CONNECTION DIAGRAMS

Head-end Equipment + Power Supply + Head-end Equipment + Network Analyzer (indirect) + Toroidals + Contactors

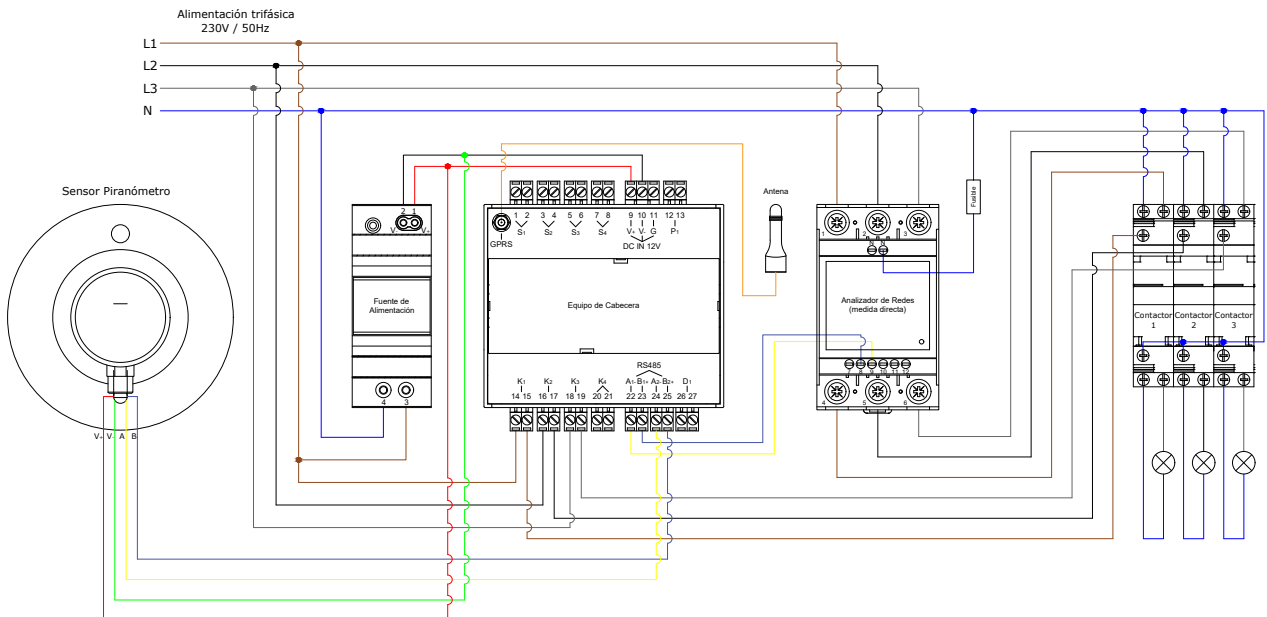

Electric parameters

| | |
|-----------------------------|-------------------------------------|
| Power supply | 12 ±2 Vdc |
| Standby power consumption | 3W |
| Input protection | With Blade medium fuse type 2A, 32V |
| Reverse polarity protection | With fuse and Schottky diode |
| Power protection | Class II |

AC voltage presence detection inputs

| | |
|--------------------------------------|---|
| Absence thresholds | $U_a < 92 \text{ Vac}$ |
| Detection thresholds | $U_d > 146 \text{ Vac}$ |
| Maximum functional isolation voltage | 630 Vpk |
| Peak overvoltage | 6.000 Vpk |
| Isolation | Optoelectric up to 3750Vrms for 1 min |
| Input protection | By 510Vpk varistor (up to 320Vacrms), power 92J, 3.5kA |

Relay outputs

| | |
|-------------------------|---|
| Maximum contact current | 5A |
| Operating voltage | 250Vac y 30Vdc |
| Input protection | 430Vpk (up to 275Vacrms), power 40J, 1.75kA |
| Type | NO |

RS485 communications

| | |
|--------------------|-----------------------------------|
| Communication mode | Half duplex - 2H |
| Baud rate | $T_x \leq 250 \text{ Kbps}$ |
| ESD protection | ±15kV on bus pins |
| TVS protection | 7V/+12V, 19A and 600W for 8/20 μs |

Digital inputs

| | |
|------------|----------------|
| Input type | Potential free |
|------------|----------------|

Mechanical parameters

| | |
|---------------------|---------------|
| IP | 20 |
| Working temperature | -20°C to 65°C |
| Dimensions | 107x90x63mm |
| Weight | 314g |

RFLIGHT₂

INTEGRATED MANAGEMENT PLATFORM FOR PUBLIC LIGHTING

SOFTWARE

INTUITIVELY DESIGNED PLATFORM ADAPTED TO ANY DEVICE

RFLight₂ allows the remote management of HISPALÉD luminaires, as well as those of other manufacturers, and integrates into any web platform, proprietary or third party, from which to operate on the lighting panels and luminaires point to point, with endless possibilities, reporting information in real time.



Platform
with intuitive
intuitive
and accessible

ALLOWS REMOTE CONTROL OF:



Installation Overview



Luminaire control



Frame control



Maintenance management



Reporting Tool



RFLight₂ GEO Installation Tool

INTEGRATES
IN ANY
WEB PLATFORM,
PROPRIETARY OR THIRD PARTY



The RFLight₂ software platform allows the integral management of the municipality's Public Lighting, both of the luminaires and of the Control Centers. From a single point of entry, it manages the registration of lighting points, inventory, management of elements, user configuration, configurable reports and maintenance of the installation.

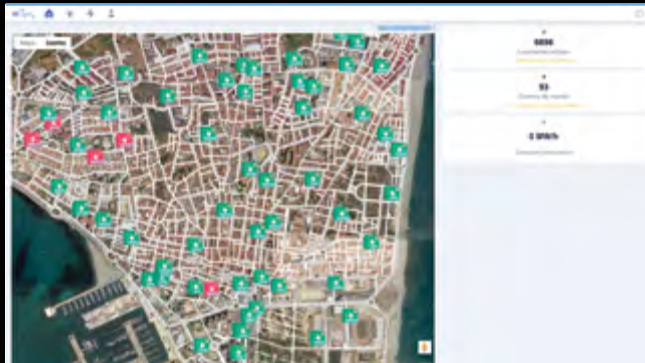

Installation overview

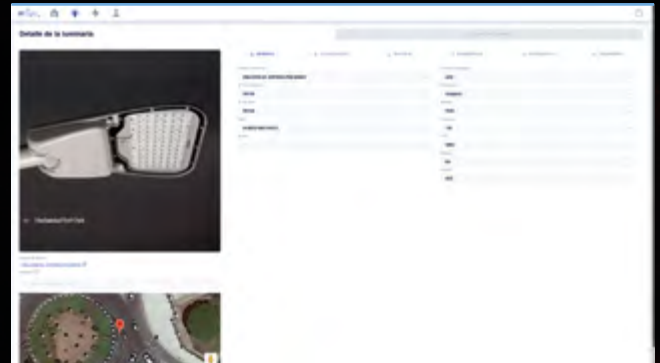

Control of luminaires

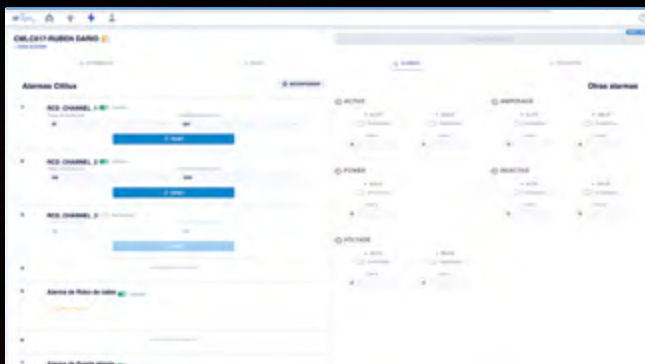

Frame control

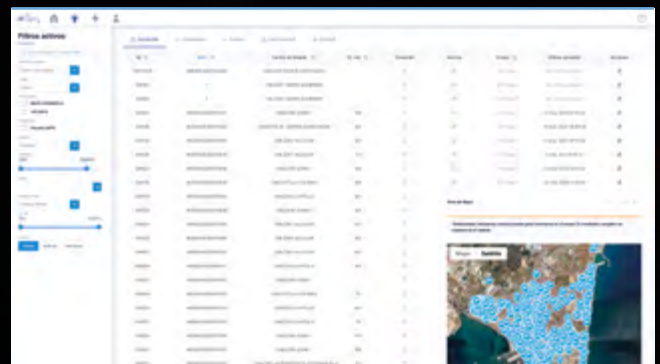

Maintenance management



Monitoring of frames

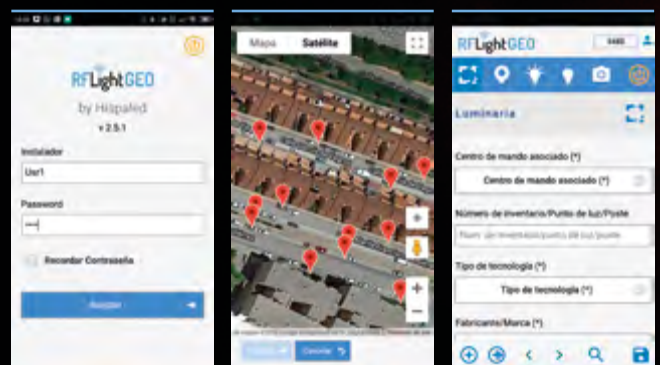

Installation tool RFLight2 GEO

RFLight GEO APP FOR INSTALLATION TEAMS, INVENTORY AND MAINTENANCE OF LUMINAIRES

The RFLight₂ Geo system allows the capture, download and processing of information from any type of equipment, especially electrical, through any mobile device based on Android or iOS.

RFLight₂ Geo is born with the vocation of:

- Eliminate a large part of the administrative tasks related to the installation of any type of equipment.
- To know, in an automated way and in real time, the status of the works.
- To provide monitoring and control tools for the teams in charge of the installation.



The system has a very simple operation: it is simply necessary to scan the QR code of the luminaire or node. In this way it is geolocated and included in a database. Optionally, the data of each location can be completed (height of the point, topology of the street, incidents, etc.).

The system includes:

- RFLight₂ Geo APP for Android and iOS. (available on Play Store and App Store).
- FIELD EQUIPMENT, consisting of a portable GPS device model Garmin GLO or similar and a 7" Samsung tablet or similar.

RFLIGHT₂ WEB, AN OPEN MANAGEMENT PLATFORM

RFLight₂ Web is the centralization point for all Smart City data. Both the headends of the command centers and the luminaire nodes, as well as the RFLight₂ Geo tool, send their data via standard protocols to the cloud, from there they are sent to the Hispaled platform. This is a unique feature of our products and our platform: IT IS A FULLY OPEN ARCHITECTURE.

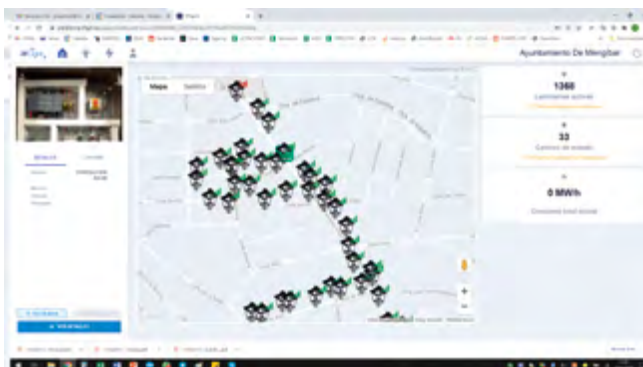

DATA AVAILABLE FOR ANY PLATFORM

We are convinced that any customer who wants to monitor and control his lighting system, whether public or private, can choose between different alternatives. Of course, not all of them from the same equipment or service provider. That is why we send the data to the cloud. So they are available to city managers from any platform.

DATA INTEGRATION FROM ANY MANUFACTURER

Similarly, we are sure that many municipalities will choose the RFLight₂ platform for their lighting control. But it is possible that not all luminaires or control centers are from Hispaled. We have a large number of success stories in which there are remote management equipment for switchboards or luminaires from third parties.



INTEGRATION OF OTHER ELEMENTS OF THE CITY

Currently, most manufacturers of data measurement equipment in a city have or will have Internet connectivity. For example, pollution or acoustic measurement stations, irrigation systems, parking lot occupancy, etc. can be incorporated into the RFLight₂ platform.

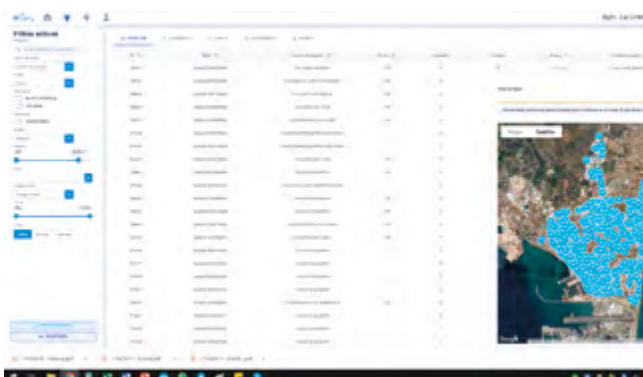



Un servicio diferente

ESPAÑA
HISPALED
MADRID / GALICIA

BOLIVIA
DELEGATION
LA PAZ

COLOMBIA
DELEGATION
BOGOTÁ

MARRUECOS
DELEGATION
CASABLANCA

Social media

